

HYDRAULIC MOTORS MLHM

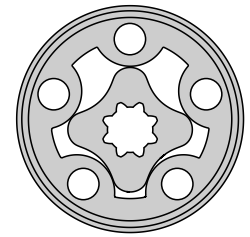

APPLICATION

- » Conveyors
- » Textile machines
- » Mining machinery
- » Machine tools
- » Ventilators
- » Construction plant equipment and access platforms etc.



CONTENTS

Specification data 5
 Performance data 6÷7
 Dimensions and mounting ... 8÷9
 Shaft extensions 10
 Permissible shaft loads 11
 Order code 12

OPTIONS

- » Model- Spool valve, gerotor
- » With or without flange
- » Side and rear ports
- » Series with pressure valve(s)
- » Shafts- straight and splined
- » SAE, Metric and BSPP ports
- » Speed sensing
- » Other special features

GENERAL

Displacement,	in ³ /rev [cm ³ /rev.]	.5÷3.05 [8,2÷50]
Max. Speed,	[RPM]	400÷1950
Max. Torque,	in-lb [daNm]	106÷398 [1,2÷4,5]
Max. Output,	HP [kW]	2.4÷3.3 [1,8÷2,4]
Max. Pressure Drop,	PSI [bar]	1015÷1500 [70÷105]
Max. Oil Flow,	GPM [lpm]	4.2÷5.5 [16÷20]
Min. Speed,	[RPM]	20÷50
Pressure fluid		Mineral based- HLP(DIN 51524) or HM(ISO 6743/4)
Temperature range,	°F [°C]	-22÷194 [-30÷90]
Optimal Viscosity range,	SUS [mm ² /s]	98÷347 [20÷75]
Filtration		ISO code 20/16 (Min. recommended fluid filtration of 25 micron)

MLHM...P Series with Integrated Internal Crossover Relief Valve
A → B, Δp=1450 or 725 PSI [100 or 50 bar]

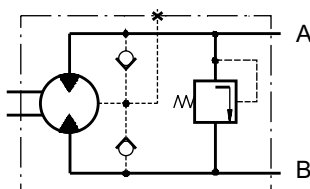

MLHM...P Series with Integrated Internal Crossover Relief Valve
B → A, Δp=1450 or 725 PSI [100 or 50 bar]

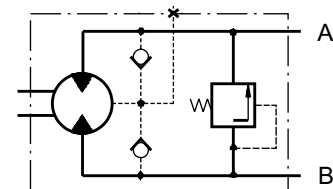

Pressure Losses

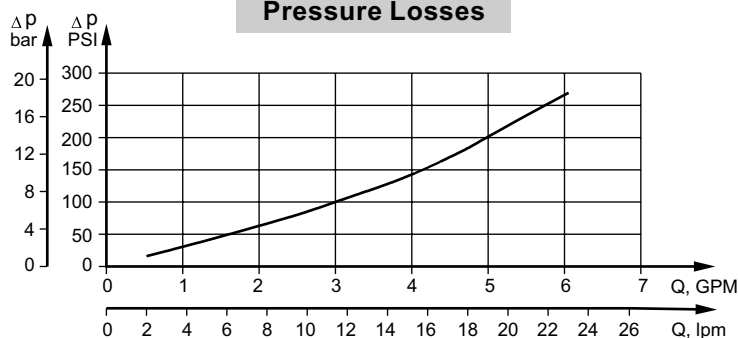

MLHM...D Series with Integrated Internal Crossover Relief Valves
A ↔ B, Δp=1450 or 725 PSI [100 or 50 bar]

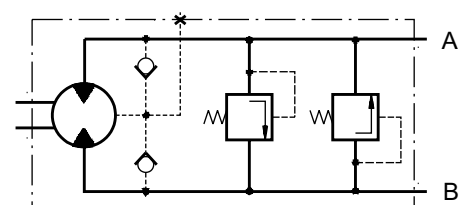

SPECIFICATION DATA

Type		MLHM 8	MLHM 12.5	MLHM 20	MLHM 32	MLHM 40	MLHM 50
Displacement, in.³/rev. [cm.³/rev.]		.5 [8,2]	.79 [12,9]	1.22 [20]	1.93 [31,8]	2.44 [40]	3.05 [50]
Max. Speed, [RPM]	Cont.	1950	1550	1000	630	500	400
	Int.*	2440	1940	1250	790	625	500
Max. Torque in-lb [daNm]	Cont.	106 [1,2]	150 [1,7]	230 [2,6]	375 [4,2]	375 [4,2]	398 [4,5]
	Int.*	133 [1,5]	205 [2,3]	311 [3,5]	506 [5,7]	506 [5,7]	513 [5,8]
	Peak**	187 [2,1]	293 [3,3]	453 [5,1]	568 [6,4]	584 [6,6]	708 [8]
Max. Output HP [kW]	Cont.	2.4 [1,8]	3.3 [2,4]	3.3 [2,4]	3.3 [2,4]	2.5 [1,8]	2.48 [1,7]
	Int.*	3.6 [2,6]	4.3 [3,2]	4.3 [3,2]	4.3 [3,2]	4 [3,0]	2.8 [2,1]
Max. Pressure Drop PSI [bar]	Cont.	1500 [105]	1500 [105]	1500 [105]	1500 [105]	1200 [82,5]	1015 [70]
	Int.*	2030 [140]	2030 [140]	2030 [140]	2030 [140]	1600 [110]	1300 [90]
	Peak**	2900 [200]	2900 [200]	2900 [200]	2900 [200]	2000 [140]	1815 [125]
Max. Oil Flow GPM [lpm]	Cont.	4.2 [16]	5.5 [20]	5.5 [20]	5.5 [20]	5.5 [20]	5.5 [20]
	Int.*	5.5 [20]	6.6 [25]	6.6 [25]	6.6 [25]	6.6 [25]	6.6 [25]
Max. Inlet Pressure PSI [bar]	Cont.	2030 [140]	2030 [140]	2030 [140]	2030 [140]	2030 [140]	2030 [140]
	Int.*	2540 [175]	2540 [175]	2540 [175]	2540 [175]	2540 [175]	2540 [175]
	Peak**	3260 [225]	3260 [225]	3260 [225]	3260 [225]	3260 [225]	3260 [225]
Max. Return Pressure without Drain Line or Max. Pressure in Drain Line, PSI [bar]	Cont. 0-100 RPM	2030 [140]	2030 [140]	2030 [140]	2030 [140]	2030 [140]	2030 [140]
	Cont. 100-400 RPM	1500 [105]	1500 [105]	1500 [105]	1500 [105]	1500 [105]	1500 [105]
	Cont. 400-800 RPM	725 [50]	725 [50]	725 [50]	725 [50]	725 [50]	725 [50]
	Cont. >800 RPM	290 [20]	290 [20]	290 [20]	-	-	-
Max. Return Pressure with Drain Line PSI [bar]	Cont.	2030 [140]	2030 [140]	2030 [140]	2030 [140]	2030 [140]	2030 [140]
	Int.*	2540 [175]	2540 [175]	2540 [175]	2540 [175]	2540 [175]	2540 [175]
	Peak**	3260 [225]	3260 [225]	3260 [225]	3260 [225]	3260 [225]	3260 [225]
Max. Starting Pressure with Unloaded Shaft, PSI [bar]		60 [4]	60 [4]	60 [4]	60 [4]	60 [4]	60 [4]
Min. Starting Torque in-lb [daNm]	At max. press. drop Cont.	65 [0,7]	105 [1,2]	190 [2,1]	300 [3,4]	295 [3,3]	330 [3,7]
	At max. press. drop Int.*	90 [1,0]	150 [1,7]	260 [2,9]	425 [4,8]	400 [4,6]	425 [4,8]
Min. Speed***, [RPM]		50	40	30	30	25	20
Weight, lb [kg]	MLHM(M) rear ports	4.2 [1,9]	4.41 [2]	4.63 [2,1]	4.85 [2,2]	5.07 [2,3]	5.51 [2,5]
	MLHMF rear ports	5.07 [2,3]	5.29 [2,4]	5.51 [2,5]	5.73 [2,6]	5.95 [2,7]	6.39 [2,9]
	MLHM(M)	5.07 [2,3]	5.29 [2,4]	5.51 [2,5]	5.73 [2,6]	5.95 [2,7]	6.39 [2,9]
	MLHMF	5.95 [2,7]	6.17 [2,8]	6.39 [2,9]	6.61 [3,0]	6.83 [3,1]	7.28 [3,3]
	MLHM(M)...P	5.51 [2,5]	5.73 [2,6]	5.95 [2,7]	6.17 [2,8]	6.39 [2,9]	6.83 [3,1]
	MLHMF...P	6.40 [2,9]	6.61 [3,0]	6.83 [3,1]	7.05 [3,2]	7.28 [3,3]	7.72 [3,5]
	MLHM(M)...D	5.73 [2,6]	5.95 [2,7]	6.17 [2,8]	6.39 [2,9]	6.61 [3,0]	7.05 [3,2]
	MLHMF...D	6.61 [3,0]	6.83 [3,1]	7.05 [3,2]	7.28 [3,3]	7.50 [3,4]	7.94 [3,6]

* Intermittent operation: the permissible values may occur for max. 10% of every minute.

** Peak load: the permissible values may occur for max. 1% of every minute.

*** For speeds of 30 RPM or lower, consult factory or your regional manager.

- Intermittent speed and intermittent pressure drop must not occur simultaneously.
- Recommended filtration is per ISO cleanliness code 20/16. A nominal filtration of 25 micron or better.
- Recommend using a premium quality, anti-wear type mineral based hydraulic oil HLP(DIN51524) or HM (ISO 6743/4).
If using synthetic fluids consult the factory for alternative seal materials.
- Recommended minimum oil viscosity 70 SUS [13 mm²/s] at 122°F [50°C].
- Recommended maximum system operating temperature is 180°F [82°C].
- To assure optimum motor life fill with fluid prior to loading and run at moderate load and speed for 15-30 minutes.



Performance Data MLHM 8

	Pressure (Δ PSI)				Max. Cont.	Max. Int.	Speed (theor.)	
	500	700	1000	1500	1740	2000		
Flow [GPM]	0.5	30.5 217	45.7 207	65.5 196	94.8 148	109 105	122 55	230
	1	30 450	44.5 447	64.5 440	98.8 405	114 371	132 314	461
	2	27 905	43.1 899	62.6 880	97.1 840	113 812	133 775	923
	3	13.9 1372	40.1 1355	60.7 1332	95.4 1292	111 1258	130 1224	1384
Max. Cont.	4.25		31.3 1924	56.7 1912	91.1 1873	106 1844	126 1791	1961
Max. Int.	5.25		0 2420	52.7 2383	88.2 2338	101 2316	122 2270	2423
Torque (theor.) in-lb. [daNm]		40.7 [0,46]	57.5 [0,65]	80.5 [0,91]	119 [1,35]	138 [1,56]	157 [1,78]	

.50 in³./rev. [8,2 cm³./rev.]

Torque [in-lb] 122
Speed [RPM] 2270

Performance Data MLHM 20

	Pressure (Δ PSI)				Max. Cont.	Max. Int.	Speed (theor.)		
	250	500	700	1000	1500	1740		2000	
Flow [GPM]	0.5	28.5 96	79 91	123 85	169 70	238 40	262 20	94,5	
	1	33 187	79.5 181	120 173	167 169	242 127	273 106	312 70	189
	2	35 378	78.5 375	115 371	163 358	244 323	278 303	318 274	379
	3	31 566	74 564	108 559	155 550	240 518	275 497	319 468	567
Max. Cont.	4	25 750	67 746	101 743	148 733	233 700	269 689	315 664	757
	5.5	13 1038	53 1035	90 1031	163 1024	218 1000	255 1993	302 1960	1040
Max. Int.	6.6		38 1247	77 1245	125 1242	206 1189	245 1180	291 1176	1250
Torque (theor.) in-lb. [daNm]		47.8 [0,54]	98 [1,11]	140 [1,59]	197 [2,23]	291 [3,29]	338 [3,82]	385 [4,36]	

1.22 in³./rev. [20 cm³./rev.]

Performance Data MLHM 12.5

	Pressure (Δ PSI)				Max. Cont.	Max. Int.	Speed (theor.)	
	500	700	1000	1500	1740	2000		
Flow [GPM]	0.5	48.3 133	70.8 129	100 113	147.4 65	164 33		146
	1	49.2 281	71.2 275	101.6 260	153 218	172 190	200 138	293
	2	46.8 575	69.1 566	100.4 554	154 516	175 488	206 446	586
	3	43.8 866	66.3 860	97.1 850	150 816	173 792	205 745	880
Max. Cont.	4	39.8 1160	63.1 1152	94.1 1144	147 1109	170 1085	203 1043	1170
	5.5	30 1604	55.6 1593	87 1582	139 1560	164 1541	195 1494	1612
Max. Int.	6.6	14.8 1910	50 1891	80 1878	132 1848	157 1828	191 1788	1937
Torque (theor.) in-lb. [daNm]		62.8 [0,71]	91.1 [1,03]	127.4 [1,44]	187.6 [2,12]	217.7 [2,46]	248.7 [2,81]	

.79 in³./rev. [12,9 cm³./rev.]

Performance Data MLHM 32

	Pressure (Δ PSI)				Max. Cont.	Max. Int.	Speed (theor.)		
	250	500	700	1000	1500	1740		2000	
Flow [GPM]	0.5	65 58	130 54	181 49	246 44	366 15		59	
	1	66 119	132 114	182 108	251 100	375 77	430 63	500 46	119
	2	62 236	128 230	177 226	252 218	377 195	433 183	506 158	238
	3	52 357	115 353	169 348	245 342	373 319	431 304	506 280	357
Max. Cont.	4	40 476	108 472	159 468	234 462	363 441	422 429	500 406	476
	5.5	24 654	88 651	144 648	220 640	345 621	406 605	480 585	654
Max. Int.	6.6	7 786	74 784	127 782	204 778	327 761	385 748	453 727	786
Torque (theor.) in-lb. [daNm]		248.7 [2,81]	248.7 [2,81]	248.7 [2,81]	248.7 [2,81]	248.7 [2,81]	248.7 [2,81]	248.7 [2,81]	

1.93 in³./rev. [31,8 cm³./rev.]

The Performance data was collected at back pressure 72.5±145 PSI [5±10 bar] and oil with viscosity of 150 SUS [32 mm²/s] at 122°F [50° C].

Performance Data MLHM 40

	Pressure (Δ PSI)				Max. Cont.	Max. Int.	Speed (theor.)	
	400	700	1000	1200	1500	1700		
Flow [GPM]	0.5	130 43	230 38	318 32	380 27	468 16	- -	46
	1	129 91	230 88	320 81	382 75	475 62	540 49	92
	2	122 187	225 185	318 173	380 167	472 158	544 146	183
	3	116 278	214 273	308 268	372 263	466 255	538 244	273
	4	102 373	202 367	296 362	360 357	462 349	532 340	365
	Max. Cont.	5.5	78 517	182 512	272 506	338 499	436 491	508 482
Max. Int.	6.6	57 622	165 617	254 612	320 607	400 600	484 591	603
Torque (theor.) in-lb. [daNm]		161 [1,82]	292 [3,3]	408 [4,62]	487 [5,5]	604 [6,82]	685 [7,74]	

Torque [in-lb] 540
Speed [RPM] 49

2.53 in³./rev. [41,5 cm³./rev.]

Performance Data MLHM 50

	Pressure (Δ PSI)				Max. Cont.	Max. Int.	Speed (theor.)
	200	400	700	1000	1285		
Flow [GPM]	0.5	90 35	185 31	308 26	434 21	- -	37
	1	92 72	182 69	308 65	438 60	550 52	74
	2	90 149	172 146	298 142	432 138	558 130	148
	3	88 225	160 222	285 219	428 215	555 207	221
	4	80 301	145 299	274 296	410 290	540 284	294
	Max. Cont.	5.5	62 415	114 414	250 411	385 406	505 396
Max. Int.	6.6	36 499	85 498	212 494	352 490	466 484	486
Torque (theor.) in-lb. [daNm]		101 [1,14]	200 [2,26]	363 [4,1]	508 [5,74]	644 [7,27]	

Torque [in-lb] 550
Speed [RPM] 52

3.14 in³./rev. [51,5 cm³./rev.]

Metric Conversions

Flow 1 lpm = .2642 GPM
Pressure 1 bar = 14.51 PSI
Torque 1 Nm = 8.85 in-lb

The Performance data was collected at back pressure 72.5÷145 PSI [5÷10 bar] and oil with viscosity of 150 SUS [32 mm²/s] at 122°F [50° C].

DIMENSIONS AND MOUNTING DATA

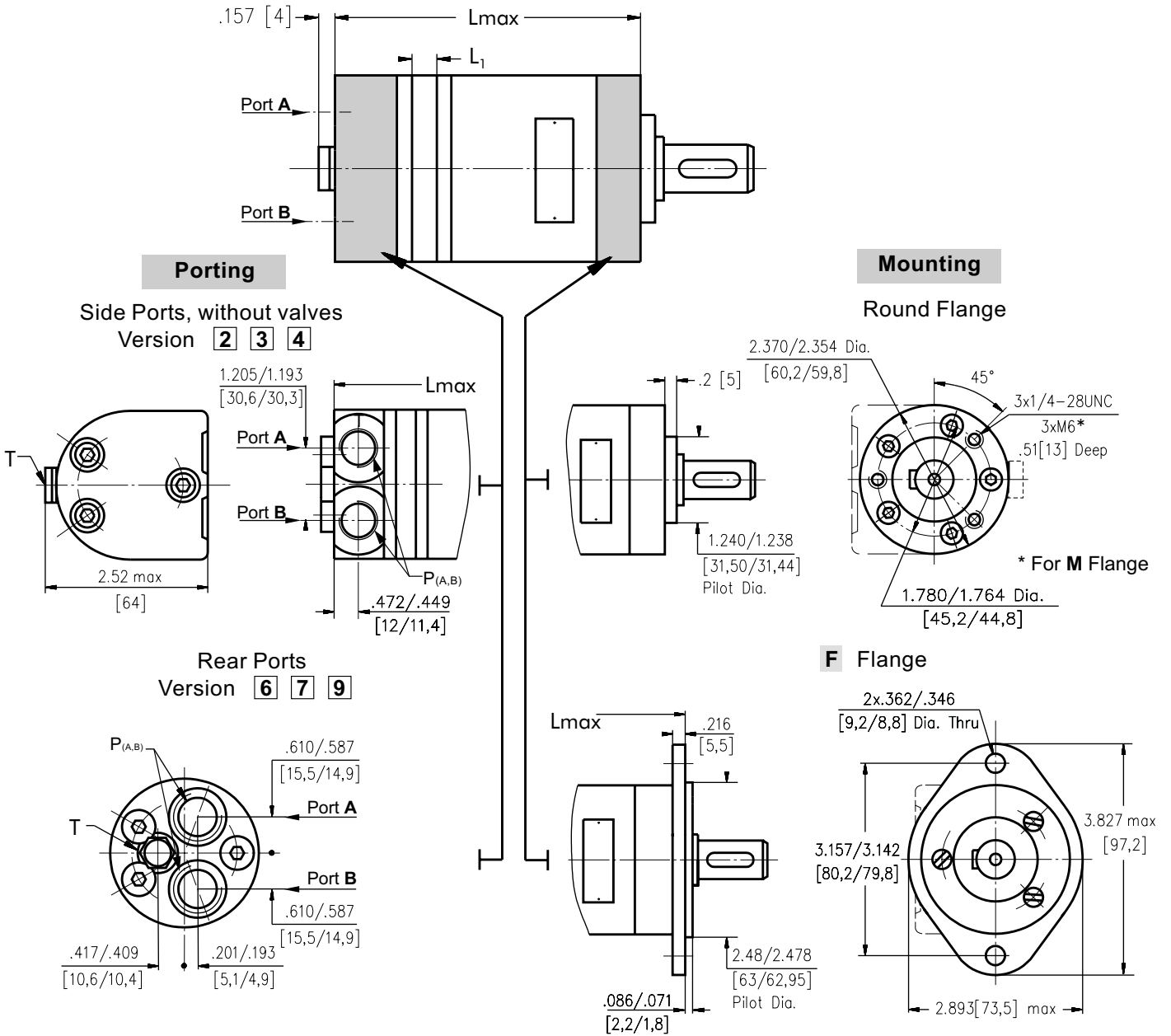

	Versions		
	2 6	3 9	4 7
P_(A,B)	2xG $\frac{3}{8}$	2xM18x1,5	2x $\frac{9}{16}$ -18UNF
T	G $\frac{1}{8}$	M10x1	$\frac{3}{8}$ -24UNF

Standard Rotation	Reverse Rotation
Viewed from Shaft End	Viewed from Shaft End
Port A Pressurized - CW	Port A Pressurized - CCW
Port B Pressurized - CCW	Port B Pressurized - CW

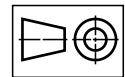

Type	Side Ports L _{max} * in.[mm]	Rear Ports L _{max} * in.[mm]	Type	Side Ports L _{max} * in.[mm]	Rear Ports L _{max} * in.[mm]	L ₁ in.[mm]
MLHM(M) 8	4.134 [105,0]	4.094 [104,0]	MLHMF 8	4.272 [108,5]	4.232 [107,5]	.138 [3,5]
MLHM(M)12.5	4.213 [107,0]	4.173 [106,0]	MLHMF 12.5	4.350 [110,5]	4.311 [109,5]	.217 [5,5]
MLHM(M) 20	4.331 [110,0]	4.291 [109,0]	MLHMF 20	4.587 [116,5]	4.547 [115,5]	.335 [8,5]
MLHM(M) 32	4.528 [115,0]	4.488 [114,0]	MLHMF 32	4.665 [118,5]	4.626 [117,5]	.531 [13,5]
MLHM(M) 40	4.665 [118,5]	4.626 [117,5]	MLHMF 40	4.803 [122,0]	4.764 [121,0]	.669 [17]
MLHM(M) 50	4.823 [122,5]	4.783 [121,5]	MLHMF 50	4.961 [126,0]	4.921 [125,0]	.827 [21]

DIMENSIONS AND MOUNTING DATA

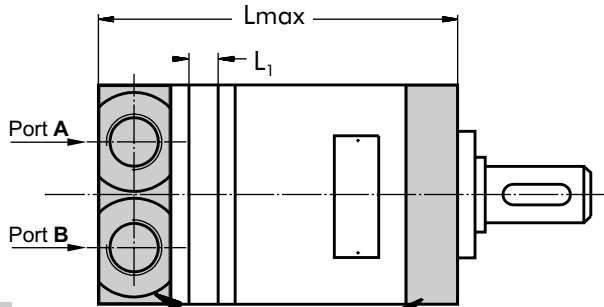

Porting

Mounting

P - Side Ports with Single Crossover Relief Valve
Version **2 3 4**

Round Flange

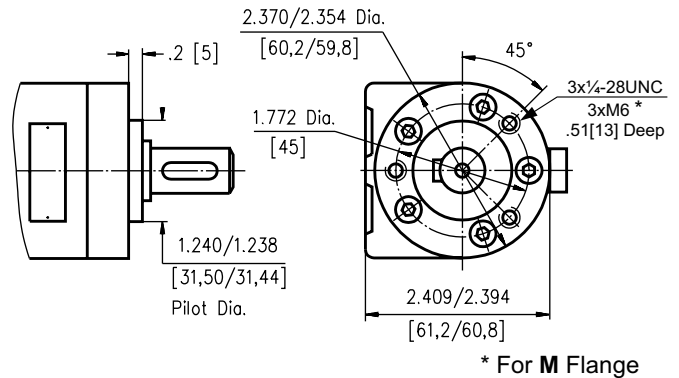
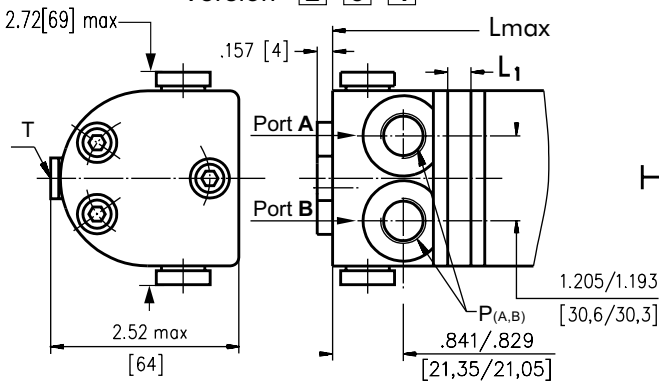

* For M Flange

D - Side Ports with Dual Crossover Relief Valve
Version **2 3 4**

F Flange

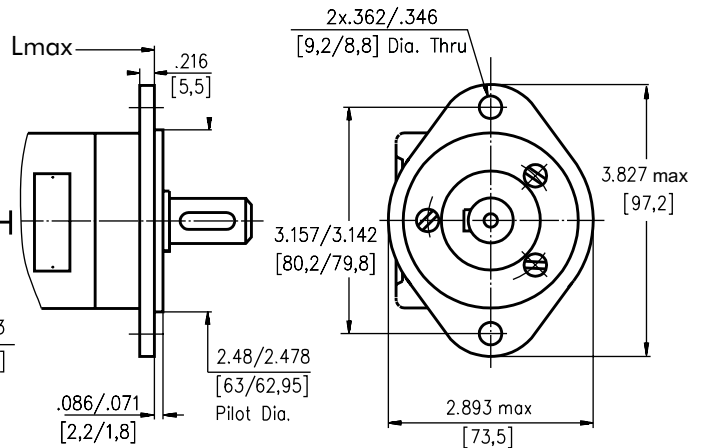
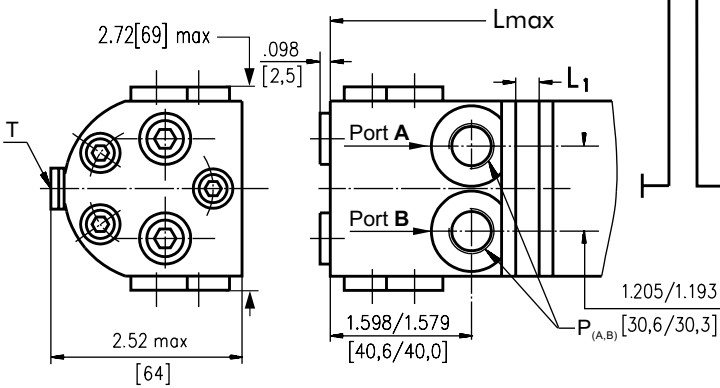

		Versions		
		2	3	4
P_(A,B)		2xG ³ / ₈	2xM18x1,5	2x ⁹ / ₁₆ -18UNF
T		G ¹ / ₈	M10x1	³ / ₈ -24UNF

Standard Rotation

Viewed from Shaft End
Port A Pressurized - **CW**
Port B Pressurized - **CCW**

Reverse Rotation

Viewed from Shaft End
Port A Pressurized - **CCW**
Port B Pressurized - **CW**

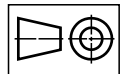

Type	L _{max} , in.[mm]	Type	L _{max} , in.[mm]	Type	L _{max} , in.[mm]	Type	L _{max} , in.[mm]	L ₁ , in.[mm]
MLHM(M) 8...P	4.528 [115]	MLHMF 8...P	4.665 [118,5]	MLHM(M) 8...D	5.276 [134,0]	MLHMF 8...D	5.433 [138]	.138 [3,5]
MLHM(M)12,5...P	4.606 [117]	MLHMF12,5...P	4.744 [120,5]	MLHM(M)12,5...D	5.354 [136,0]	MLHMF12,5...D	5.512 [140]	.217 [5,5]
MLHM(M) 20...P	4.724 [120]	MLHMF 20...P	4.862 [123,5]	MLHM(M) 20...D	5.472 [139,0]	MLHMF 20...D	5.748 [146]	.335 [8,5]
MLHM(M) 32...P	4.921 [125]	MLHMF 32...P	5.059 [128,5]	MLHM(M) 32...D	5.669 [144,0]	MLHMF 32...D	5.827 [148]	.531 [13,5]
MLHM(M) 40...P	5.039 [128]	MLHMF 40...P	5.197 [132,0]	MLHM(M) 40...D	5.807 [147,5]	MLHMF 40...D	5.945 [151]	.669 [17]
MLHM(M) 50...P	5.217 [132,5]	MLHMF 50...P	5.354 [136,0]	MLHM(M) 50...D	5.965 [151,5]	MLHMF 50...D	6.102 [155]	.828 [21]

SHAFT EXTENSIONS

C

$\frac{5}{8}$ " [15,8] straight, Parallel key $\frac{3}{16}$ "x $\frac{3}{16}$ "x $\frac{3}{4}$ " BS 46
Max. Torque 345 in-lb [3,9 daNm]

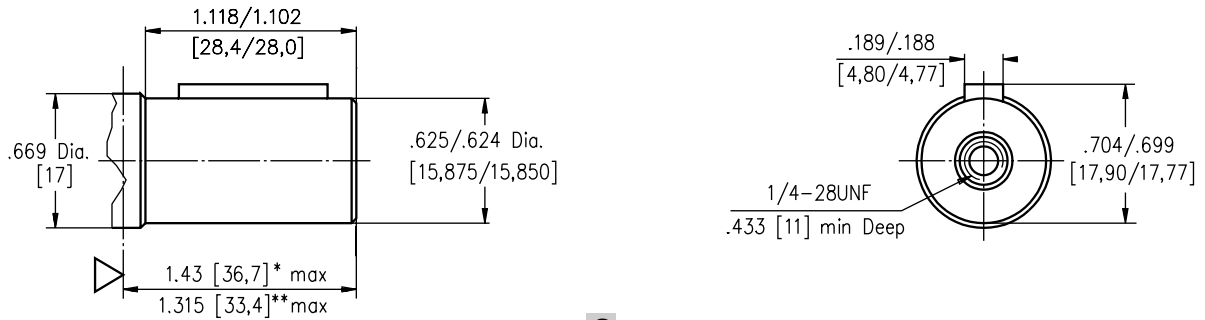

G

Splined - Metric B 17x14 DIN 5482
Max. Torque 390 in-lb [4,4 daNm]

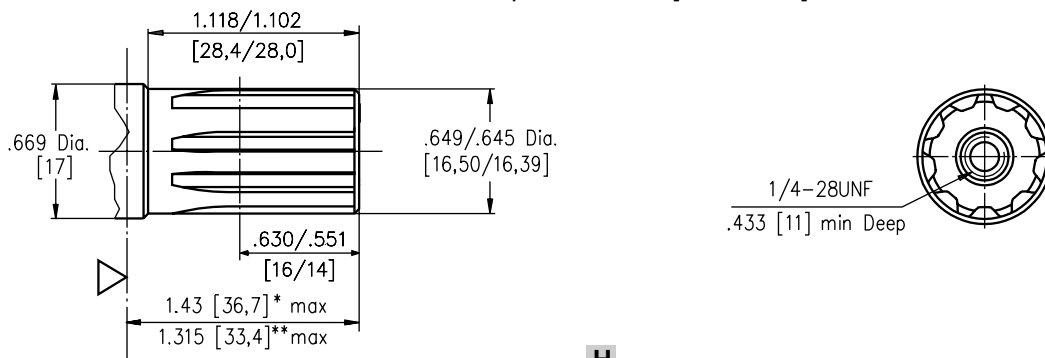

H

$\frac{5}{8}$ " [15,8] straight, w/ .19 [4,82] Crosshole
Max. Torque 345 in-lb [3,9 daNm]

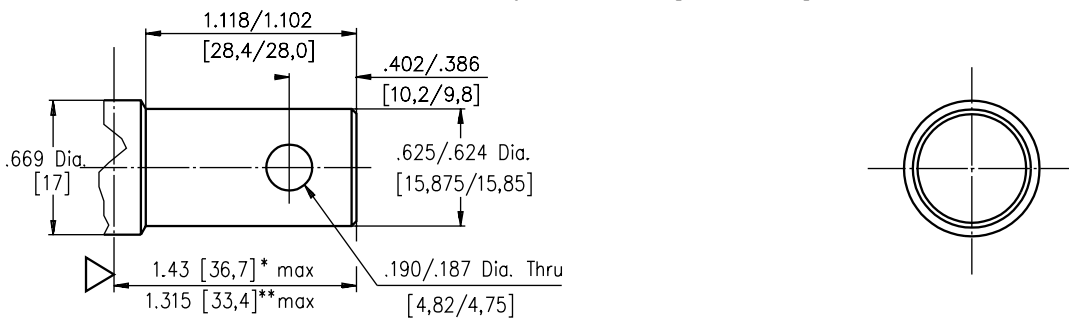

M

ø16 straight, Parallel key A5x5x16 DIN 6885
Max. Torque 345 in-lb [3,9 daNm]

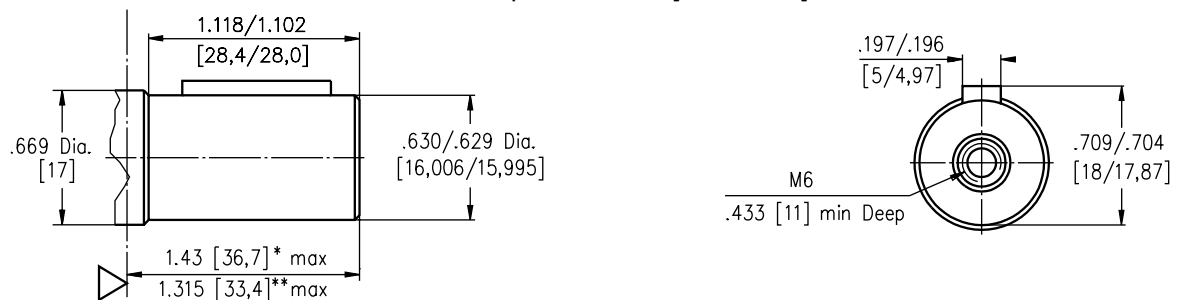

* For Round Flange
** For Flange F

▽ - Motor Mounting Surface
Requirement max. Torque must be not exceeded.

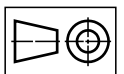

PERMISSIBLE SHAFT LOAD

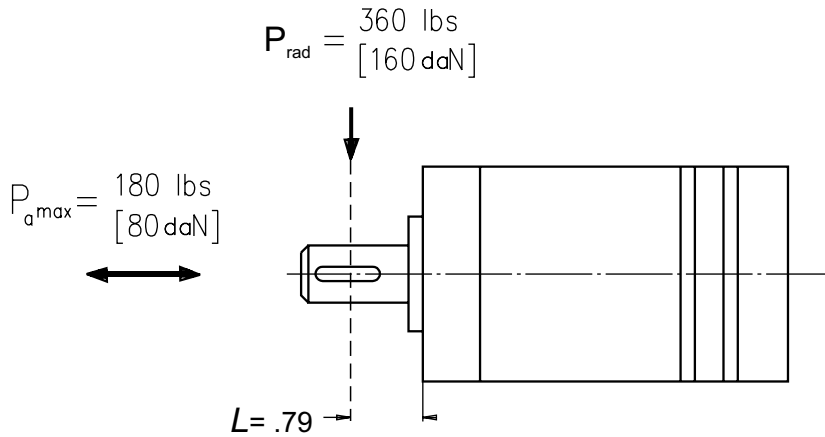

The permissible radial shaft load P_{rad} is calculated from the distance L between the point of load application and the mounting surface:

$$* P_{rad} = \frac{600}{n} \times \frac{1155}{2.42 + L}, \text{ [lbs]}$$

- * 1. L - in inch
- 2. $L \leq 3.12$

The drawing shows the permissible radial load when $L = .79$.

If the calculated shaft load exceeds the permissible, a flexible coupling must be used.

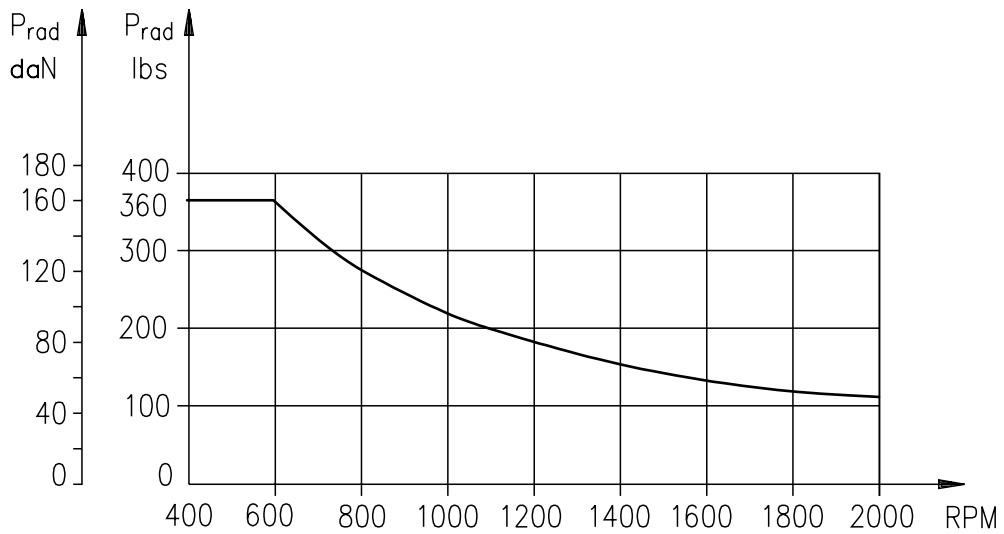

ORDER CODE

1	2	3	4	5	6	7	8	9	
M	L	H	M						

Pos.1 - Mounting Flange

omit - round, three bolts

F - flange, two holes

M - round metric, three bolts M6

Pos.2 - Displacement code

8 - .5 [8,2] in.³/rev. [cm.³/rev.]

12.5 - .79 [12,9] in.³/rev. [cm.³/rev.]

20 - 1.22 [20,0] in.³/rev. [cm.³/rev.]

32 - 1.93 [31,8] in.³/rev. [cm.³/rev.]

40 - 2.44 [40,0] in.³/rev. [cm.³/rev.]

50 - 3.05 [50,0] in.³/rev. [cm.³/rev.]

Pos.3 - Shaft Extensions* [for dimensions data see page 10]

C - ⁵/₈" [15,8] straight, Parallel key

VC - ⁵/₈" [15,8] straight, Parallel key w/ corrosion resistant bushing

G - Involute Splined- Metric B17x14 DIN5482

H - ⁵/₈" [15,8] straight, Parallel key w/ .19 [4,82] Crosshole

M - 16 mm straight, Parallel key

VM - 16 mm straight, Parallel key w/ corrosion resistant bushing

Pos.4 - Port Size/Type [standard manifold to each]

2 - side ports, 2xG3/8, G1/8, BSP thread, ISO 228

3 - side ports, 2xM18x1,5; M10x1; metric thread, ISO 262

4 - side ports, 2x9/16-18 UNF, O-ring, 3/8-24 UNF

6 - rear ports, 2xG3/8, G1/8, BSP thread, ISO 228

7 - rear ports, 2x9/16-18 UNF, O-ring, 3/8-24 UNF

9 - rear ports, 2xM18x1,5; M10x1; metric thread, ISO 262

Pos. 5 - Option**

omit - without valves

D - side ports with dual crossover relief valve

P - side ports with single crossover relief valve

Pos. 6 - Directions for Control [for "P" option only]

/L - B → A (left control)

/R - A → B (right control)

Pos. 7 - Valve Rated Pressure [for "P" and "D" option only]

/50 - Δp= 725 PSI [50 bar]

/100 - Δp=1450 PSI [100 bar]

Pos. 8 - Special Features [see page 52]

Pos. 9 - Design Series

omit - Factory specified

Notes: * The permissible output torque for shafts must not be exceeded!

** Options **P, D**- for side ports (**2, 3, 4**) only.

The hydraulic motors are mangano-phosphatized as standard.

F - Flange Kit (2 Holes)

Order No:48443 029 00

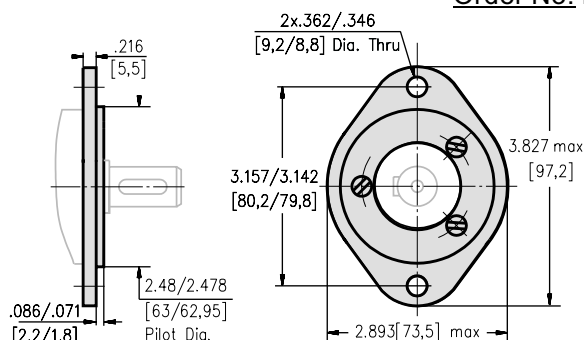

Flange Kit includes 3 screws - 1/4-28 UNF for attaching flange to the motor.