

HYDRAULIC MOTORS MLHH

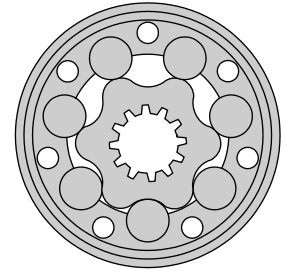

APPLICATION

- » Conveyors
- » Feeding mechanism of robots and manipulators
- » Metal working machines
- » Textile machines
- » Machines for agriculture
- » Food industries
- » Mining machinery etc.



CONTENTS

Specification data	45
Performance data	46÷48
Permissible shaft loads	48
Dimensions and mounting.....	49
Permissible shaft seal pressure....	50
Shaft extensions	51
Order code	51

OPTIONS

- » Model- Spool valve, roll-gerotor
- » Flange mount
- » Shafts- straight, splined and tapered
- » SAE, Metric and BSPP ports
- » Speed sensing
- » Other special features

GENERAL

Displacement,	in ³ /rev [cm ³ /rev.]	12.3÷30.7 [201,3÷502,4]
Max. Speed,	[RPM]	150÷370
Max. Torque,	in-lb [daNm]	4510÷7434 [51÷84]
Max. Output,	HP [kW]	11÷21 [8,5÷16]
Max. Pressure Drop,	PSI [bar]	1300÷2540 [90÷175]
Max. Oil Flow,	GPM [lpm]	20 [75]
Min. Speed,	[RPM]	5÷10
Pressure fluid		Mineral based- HLP(DIN 51524) or HM(ISO 6743/4)
Temperature range,	°F [°C]	-22÷194 [-30÷90]
Optimal Viscosity range, SUS [mm²/s]		98÷347 [20÷75]
Filtration		ISO code 20/16 (Min. recommended fluid filtration of 25 micron)

Oil flow in drain line

Pressure drop PSI [bar]	Viscosity SUS [mm ² /s]	Oil flow in drain line GPM [lpm]
1450 [100]	98 [20]	.660 [2,5]
	164 [35]	.476 [1,8]
2030 [140]	98 [20]	.925 [3,5]
	164 [35]	.740 [2,8]

Pressure Losses

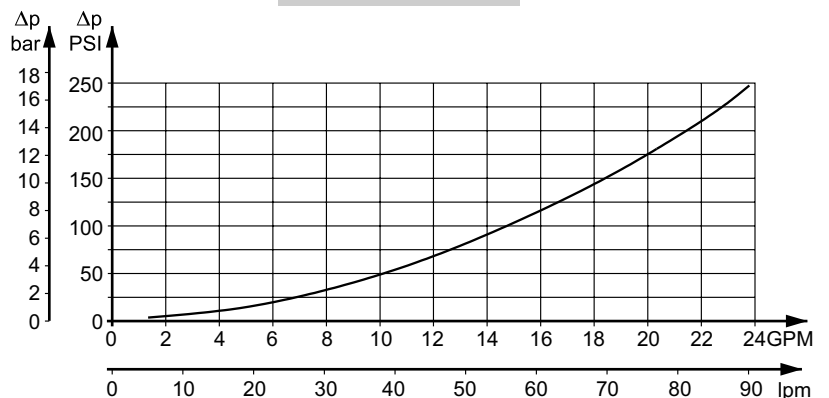

SPECIFICATION DATA

Type		MLHH 200	MLHH 250	MLHH 315	MLHH 400	MLHH 500
Displacement, in.³/rev. [cm.³/rev.]		12.3 [201,3]	15.4 [252]	16.4 [314,9]	24.2 [396,8]	30.7 [502,4]
Max. Speed, [RPM]	Cont.	370	295	235	185	150
	Int.*	445	350	285	225	180
Max. Torque in-lb [daNm]	Cont.	4510 [51]	5398 [61]	6548 [74]	7434 [84]	7257 [82]
	Int.*	5130 [58]	6195 [70]	7257 [82]	8673 [98]	9204 [104]
	Peak**	5064 [64]	6992 [79]	8673 [98]	9647 [109]	10350 [117]
Max. Output HP [kW]	Cont.	21 [16]	21 [16]	18.7 [14]	16.7 [12,5]	14.7 [11]
	Int.*	24.8 [18,5]	4.8 [18,5]	20.7 [15,5]	20.1 [15]	18.7 [14]
Max. Pressure Drop PSI [bar]	Cont.	2540 [175]	2540 [175]	2540 [175]	2240 [155]	1740 [120]
	Int.*	2900 [200]	2900 [200]	2900 [200]	2750 [190]	2100 [145]
	Peak**	3260 [225]	3260 [225]	3260 [225]	3045 [210]	2390 [165]
Max. Oil Flow GPM [lpm]	Cont.	20 [75]	20 [75]	20 [75]	20 [75]	20 [75]
	Int.*	24 [90]	24 [90]	24 [90]	24 [90]	24 [90]
Max. Inlet Pressure PSI [bar]	Cont.	2900 [200]	2900 [200]	2900 [200]	2900 [200]	2900 [200]
	Int.*	3260 [225]	3260 [225]	3260 [225]	3260 [225]	3260 [225]
	Peak**	3626 [250]	3626 [250]	3626 [250]	3626 [250]	3626 [250]
Max. Starting Pressure with Unloaded Shaft, PSI [bar]		72 [5]	72 [5]	72 [5]	72 [5]	72 [5]
Min. Starting Torque, in-lb [daNm]	At max.press.dropCont	3450 [39]	4600 [52]	5840 [66]	6370 [72]	6370 [72]
	At max.press.drop Int.*	3980 [45]	5221 [59]	6460 [73]	7788 [88]	7788 [88]
Min. Speed***, [RPM]		10	10	8	5	5
Weight, lb [kg]		23.2 [10,5]	24.3 [11]	25.4 [11,5]	27.1 [12,3]	28.7 [13]

* Intermittent operation: the permissible values may occur for max. 10% of every minute.

** Peak load: the permissible values may occur for max. 1% of every minute.

*** For speeds of 5 RPM lower than given, consult factory or your regional manager.

- 1) Intermittent speed and intermittent pressure must not occur simultaneously.
- 2) Recommended filtration is per ISO cleanliness code 20/16. A nominal filtration of 25 micron or better.
- 3) Recommend using a premium quality, anti-wear type mineral based hydraulic oil, HLP(DIN51524) or HM(ISO6743/4).
If using synthetic fluids consult the factory for alternative seal materials.
- 4) Recommended minimum oil viscosity 70 SUS [13 mm²/s] at 122°F [50°C].
- 5) Recommended maximum system operating temperature is 180°F [82°C].
- 6) To assure optimum motor life fill with fluid prior to loading and run at moderate load and speed for 10-15 minutes.



Performance Data MLHH 200

		Pressure (Δ PSI)					Max. Cont.	Max. Int.	Speed (theor.)
		500	1000	1500	2000	2540	2900		
Flow [GPM]	1	850 22	1679 20	2452 17	- -	- -	-	-	25
	3	872 49	1758 47	2599 42	3377 33	4229 16	-	-	50
	5	856 96	1740 93	2630 89	3468 81	4466 66	5053	53	99
	8	839 148	1705 146	2595 142	3475 133	4479 116	5080	103	149
	10	774 195	1640 194	2521 191	3442 180	4449 161	5064	146	198
	13	705 246	1583 244	2453 242	3389 233	4390 212	5008	198	248
	16	634 298	1500 296	2364 293	3319 284	4329 265	4938	249	296
	18	544 346	1411 344	2283 343	3229 332	4217 312	4861	296	347
Max. Cont.	20	509 373	1358 372	2239 370	3165 362	4170 341	4793	325	372
Max. Int.	22	455 400	1296 400	2188 399	3092 390	4086 370	4720	355	412
	24	341 447	1206 445	2081 442	3004 434	4001 414	4613	399	447
Torque (theor.) in-lb. [daNm]		977 [11]	1953 [22]	2929 [33,1]	3907 [44,1]	4961 [56]	5665 [64]	Torque [in-lb] 4613 Speed [RPM] 399	

12.3 in.³/rev. [201,3 cm.³/rev.]

Performance Data MLHH 250

		Pressure (Δ PSI)					Max. Cont.	Max. Int.	Speed (theor.)	
		500	1000	1300	1700	2100	2540	2900		
Flow [GPM]	1	1040 18	2111 16	2760 14	3387 11	- -	- -	- -	20	
	3	1117 39	2214 38	2872 36	3618 33	4486 27	5186 14	- -	40	
	5	1113 76	2215 74	2886 73	3679 70	4530 62	5413 51	6119	40	79
	8	1050 118	2155 116	2841 114	3653 108	4530 98	5416 86	6103	77	119
	10	986 156	2062 154	2800 150	3597 144	4463 134	5371 122	6079	110	159
	13	904 196	1991 195	2723 192	3502 185	4394 173	5285 159	5990	147	198
	16	810 238	1891 236	2623 232	3411 224	4318 211	5200 197	5893	185	238
	18	699 275	1793 274	2502 272	3313 263	4216 249	5080 235	5805	219	277
Max. Cont.	20	618 297	1741 296	2433 294	3243 286	4132 273	5007 257	5740	242	297
Max. Int.	22	566 320	1665 319	2373 315	3156 307	4062 295	4938 279	5669	263	329
	24	423 357	1530 356	2226 353	3025 345	3947 333	4812 317	5529	299	357
Torque (theor.) in-lb. [daNm]		1224 [13,8]	2450 [27,7]	3185 [35,9]	4165 [47]	5144 [58,1]	6221 [70,3]	7104 [80,26]	Torque [in-lb] 5529 Speed [RPM] 299	

15.4 in.³/rev. [252 cm.³/rev.]

The Performance data was collected at back pressure 72.5÷145 PSI [5÷10 bar] and oil with viscosity of 150 SUS [32 mm²/s] at 122°F [50°C].



Performance Data MLHH 315

		Pressure (Δ PSI)					Max. Cont.	Max. Int.	Speed (theor.)
		500	1100	1500	1900	2250	2540	2900	
Flow [GPM]	1	1348 14	2901 10	- -	- -	- -	- -	- -	16
	3	1419 31	3051 28	4136 21	4754 16	- -	- -	- -	32
	5	1465 61	3115 58	4279 52	4976 46	5860 38	6468 30	7131 18	64
	8	1430 94	3069 90	4289 83	4960 78	5908 68	6529 60	7262 47	95
	10	1338 123	3002 121	4245 113	4937 106	5853 94	6507 84	7292 69	127
	13	1223 157	2899 153	4152 146	4861 137	5788 124	6427 114	7261 97	158
	16	1047 190	2783 189	4016 181	4748 171	5672 156	6311 145	7161 126	190
	18	896 220	2656 219	3880 210	4626 200	5571 183	6200 172	7053 153	222
Max. Cont.	20	819 239	2562 236	3802 227	4529 218	5495 199	6142 186	6985 168	238
Max. Int.	22	713 257	2467 255	3702 247	4433 238	5395 220	6069 206	6915 182	263
	24	539 286	2287 284	3520 278	4240 269	5234 251	5903 237	6758 212	286
Torque (theor.) in-lb. [daNm]		1529 [17,3]	3363 [38]	4587 [51,8]	5810 [65,6]	6880 [77,7]	7768 [87,7]	8869 [100,2]	Torque [in-lb] 6758 Speed [RPM] 212
19.2 in. ³ /rev. [314,9 cm. ³ /rev.]									

Performance Data MLHH 400

		Pressure (Δ PSI)					Max. Cont.	Max. Int.	Speed (theor.)
		500	900	1400	1800	2240	2750		
Flow [GPM]	1	1670 11	3109 10	4102 8	- -	- -	- -	- -	13
	3	1741 26	3247 25	4338 24	6021 20	7394 13	- -	- -	25
	5	1782 48	3274 47	4311 45	6073 40	7525 35	8521 30	- -	50
	8	1715 75	3193 74	4310 72	6062 65	7442 58	8484 53	- -	76
	10	1658 97	3090 95	4226 93	6016 83	7391 75	8394 69	- -	101
	13	1474 125	2964 123	4114 119	5891 108	7306 98	8265 91	- -	126
	16	1309 151	2851 149	3978 146	5732 132	7176 119	8139 110	- -	151
	18	1178 174	2723 172	3814 168	5570 155	7011 140	7979 130	- -	176
Max. Cont.	20	1090 189	2626 187	3704 183	5462 169	6905 154	7857 143	- -	189
Max. Int.	22	958 205	2477 204	3587 200	5328 186	6771 168	7753 154	- -	209
	24	767 227	2289 227	3439 222	5102 209	6605 189	7600 171	- -	227
Torque (theor.) in-lb. [daNm]		1929 [22]	3472 [39,2]	5400 [61]	6944 [78]	8642 [97,6]	10609 [119,9]		Torque [in-lb] 7600 Speed [RPM] 171
24.2 in. ³ /rev. [396,8 cm. ³ /rev.]									

The Performance data was collected at back pressure 72.5÷145 PSI [5÷10 bar] and oil with viscosity of 150 SUS [32 mm²/s] at 122°F [50°C].



Performance Data MLHH 500

	Pressure (Δ PSI)					Max. Cont.	Max. Int.	Speed (theor.)
	350	700	1200	1500	1800	2300		
Flow [GPM]	1	1640 7	3010 6	5013 5	6351 5	7223 4	8898 3	8
	3	1640 22	3192 20	5243 19	6546 17	7692 13	9272 11	23
	5	1685 37	3101 36	5335 34	6595 32	7786 29	9553 25	38
	8	1640 59	3101 58	5243 55	6448 52	7692 50	9553 44	60
	10	1457 73	2918 69	4967 71	6155 67	7598 62	9366 55	75
	13	1366 97	2827 96	4967 91	6351 88	7317 85	9179 75	98
	16	1184 120	2645 119	4875 112	6057 108	7223 101	9038 95	121
	18	911 133	2462 129	4645 128	5862 125	7082 118	8804 87	136
Max. Cont.	20	774 149	2371 147	4599 145	5667 141	6942 133	8711 120	151
Max. Int.	22	547 164	2234 163	4415 160	5569 153	6895 147	8617 135	166
	24	501 176	2006 174	4231 168	5471 171	6567 161	8430 147	181
Torque (theor.) in-lb. [daNm]		1709 [19,3]	3418 [38,6]	5859 [66,2]	7325 [82,7]	8790 [99,3]	11231 [126,9]	

30.7 in.³/rev. [502,4 cm.³/rev.]

Torque [in-lb] 7828
 Speed [RPM] 157

Metric Conversions

Flow 1 lpm = 0.264 GPM
 Pressure 1 bar = 14.51 PSI
 Torque 1 Nm = 8.85 in-lb

The Performance data was collected at back pressure 72.5÷145 PSI [5÷10 bar] and oil with viscosity of 150 SUS [32 mm²/s] at 122°F [50°C].

PERMISSIBLE SHAFT LOADS FOR MLHH MOTORS

The permissible radial shaft load P_{rad} depends on the speed (RPM) and distance (L) from the point of load to the mounting flange.

$$\text{Radial Shaft Load } P_{rad} = \frac{1100}{\text{RPM}} \times \frac{2215}{4.075+L}, \text{ daN}^*$$

*L < 2.362 in [60 mm]; n ≥ 200 min⁻¹

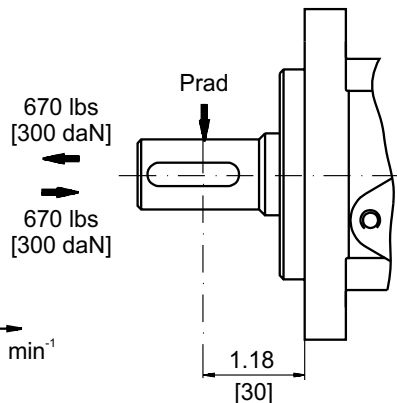
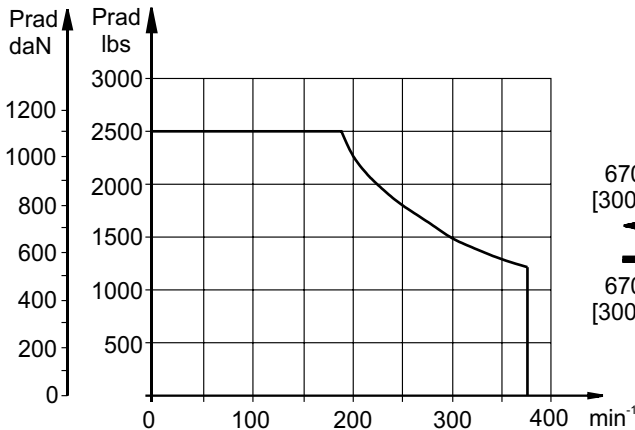

DIMENSIONS AND MOUNTING DATA

Magneto Mounting Flange with 4 hole

Type	L, mm	L ₁ , mm
MLHH 200	6.65 [169]	1.09 [27,8]
MLHH 250	6.93 [176]	1.37 [34,8]
MLHH 315	7.24 [184]	1.71 [43,5]
MLHH 400	7.72 [196]	2.16 [54,8]
MLHH 500	8.31 [211]	2.73 [69,4]

Standard Rotation
Viewed from Shaft End
Port A Pressurized - **CW**
Port B Pressurized - **CCW**

Reverse Rotation
Viewed from Shaft End
Port A Pressurized - **CCW**
Port B Pressurized - **CW**

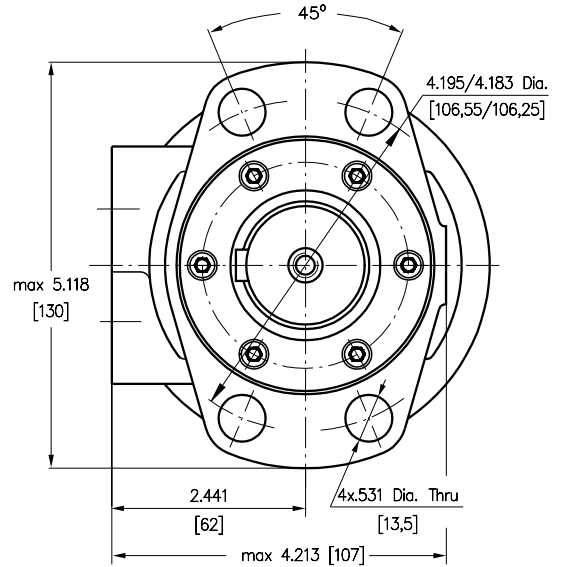

	Versions			
	2	3	4	5
C	4xM8	4xM8	4x $\frac{5}{16}$ -18UNC	4x $\frac{5}{16}$ -18UNC
P_(A,B)	2xG $\frac{1}{2}$	2xM22x1,5	2x $\frac{7}{8}$ -14UNF	2x $\frac{1}{2}$ -14NPTF
T	G $\frac{1}{4}$	M14x1,5	$\frac{7}{16}$ -20UNF	$\frac{7}{16}$ -20UNF

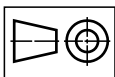
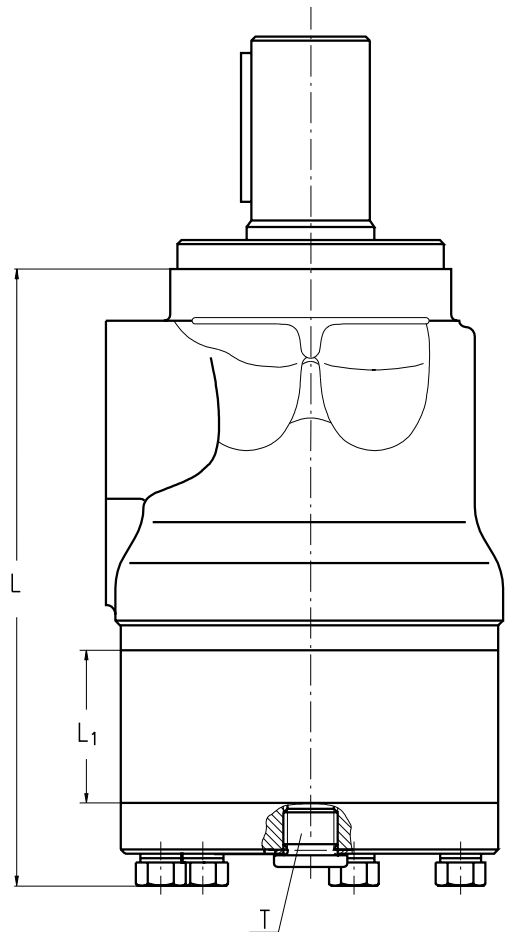
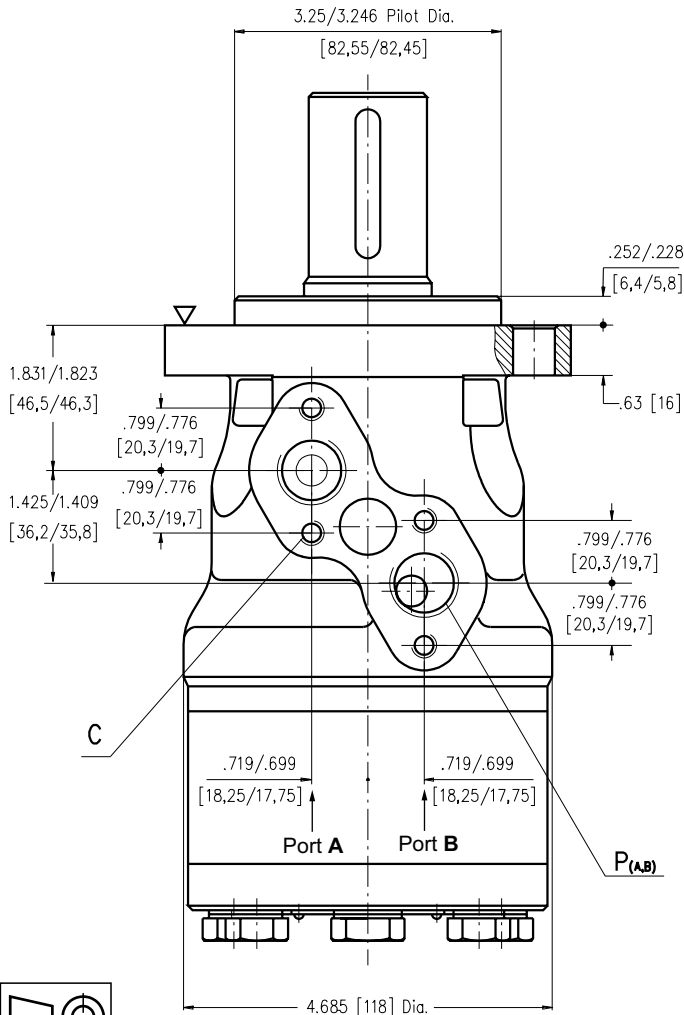

**MAX. PERMISSIBLE SHAFT SEAL PRESSURE
FOR MLHH MOTORS**

MLHH...U1 motors with high pressure seal and without drain connection:

The shaft seal pressure equals the average of input pressure and return pressure.

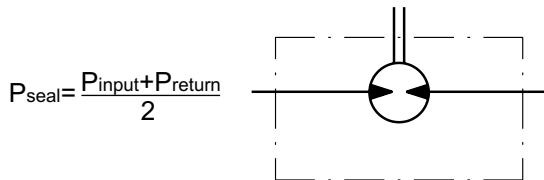

MLHH...U motors with high pressure seal and drain connection:

The shaft seal pressure equals the pressure in the drain line.

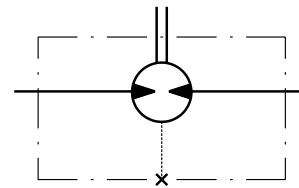

MLHH...1 motors with standard shaft seal and without drain connection:

The shaft seal pressure never exceeds the pressure in the return line.

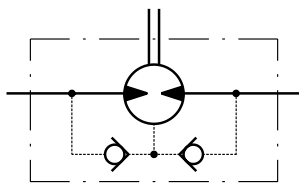

MLHH... motors with standard shaft seal and with drain connection:

The shaft seal pressure equals the pressure in the drain line.

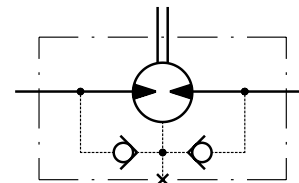

**Max. return pressure without drain line or
max. pressure in the drain line**

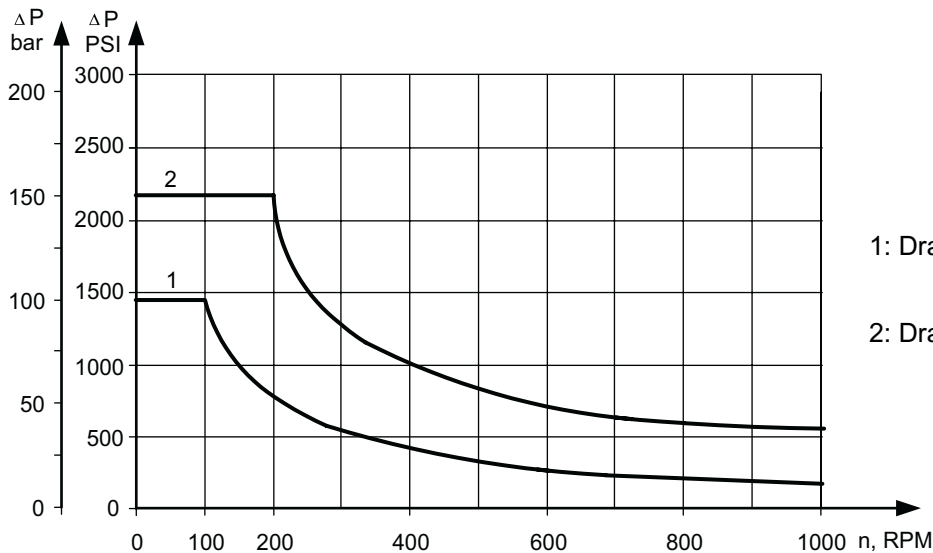

1: Drawing for Standard Shaft Seal

2: Drawing for High Pressure Seal ("U" Seal)

SHAFT EXTENSIONS

K

1 1/4" [31,75] straight, Parallel key 5/16"x 5/16"x1 1/4" BS 46
Max. Torque 6815 in-lb [77 daNm]

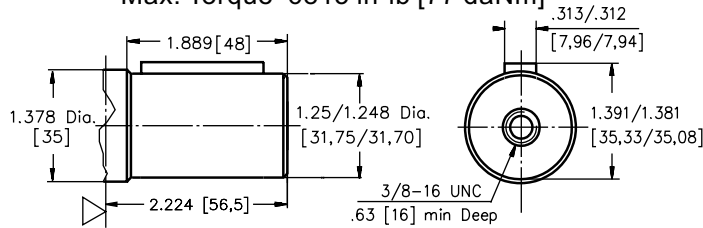

B

ø35 straight, Parallel key A10x8x45 DIN 6885
Max. Torque 8400 in-lb [95 daNm]

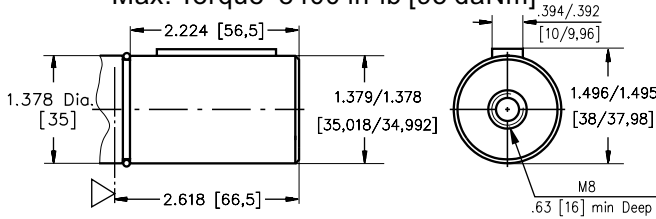

M

ø32 straight, Parallel key A10x8x45 DIN 6885
Max. Torque 6815 in-lb [77 daNm]

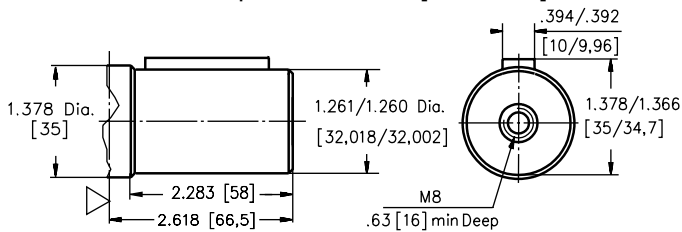

L

14T Splined, 1 1/4" [31,75], ANS B 92.1-1976
Max. Torque 8400 in-lb [95 daNm]

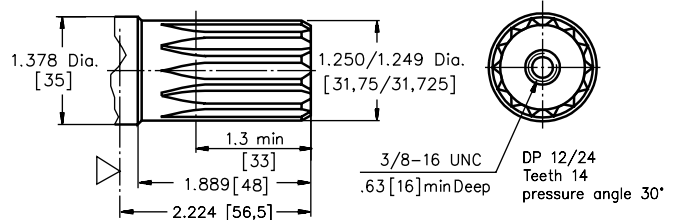

R

1 1/4" [31,75], SAE J501 Tapered, Parallel key 5/16"x 5/16"x1"
Max. Torque 8400 in-lb [95 daNm]

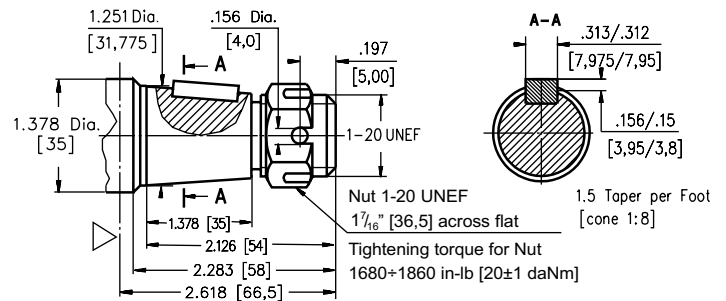

△- Motor Mounting Surface Requirement max. Torque must be not exceeded.

ORDER CODE

1	2	3	4	5	6	7
MLHH						

Pos.1 - Displacement code

200	- 12.3 [201,3] in. ³ /rev. [cm. ³ /rev.]
250	- 15.4 [252,0] in. ³ /rev. [cm. ³ /rev.]
315	- 16.4 [314,9] in. ³ /rev. [cm. ³ /rev.]
400	- 24.2 [396,8] in. ³ /rev. [cm. ³ /rev.]
500	- 30.7 [502,4] in. ³ /rev. [cm. ³ /rev.]

Pos.2 - Shaft Extensions*

K	- 1 1/4" [31,75] straight, Parallel key
L	- 1 1/4" [31,75] Splined 14T ANS B92.1-1970
B	- ø35 straight, Parallel key
R	- 1 1/4" [31,75] SAE J501 Tapered
M	- ø32 straight, Parallel key

Pos.3 - Port Size/Type [standard manifold to each]

2	- side ports, 2xG1/2, G1/4, BSP thread, ISO 228
3	- side ports, 2xM22x1,5, M14x1,5, metric thread, ISO 262
4	- side ports, 2x7/8-14 UNF, O-ring, 7/16-20 UNF
5	- side ports, 2x1/2-14 NPTF, 7/16-20 UNF

Pos.4 - Shaft Seal Version [see page 50]

omit	- Standard shaft seal
U	- High pressure shaft seal (without check valves)

Pos.5 - Drain Port

omit	- with drain port
1	- without drain port

Pos.6 - Special Features [see page 52]

Pos.7 - Design Series

omit	- Factory specified
------	---------------------

Notes : * The permissible output torque for shafts must not be exceeded!

The hydraulic motors are mangano-phosphatized as standard.