

STEERING COLUMNS TYPE KK...



The M+S Hydraulic KK Steering Columns transfer the torque from the steering wheel of the vehicle to the HKU, HKUS or other of the same class steering units. The KK steering columns are consisted of a pipe in which is centered the control shaft.

Permissible loads on the steering column are as follows:

Max. torque applied to the steering wheel 24 daNm
 Max. bending moment 20 daNm
 Max. axial load 100 daN

The steering column must be additionally supported when the length L exceeds 150 mm.

DIMENSIONS AND MOUNTING DATA

Type KK

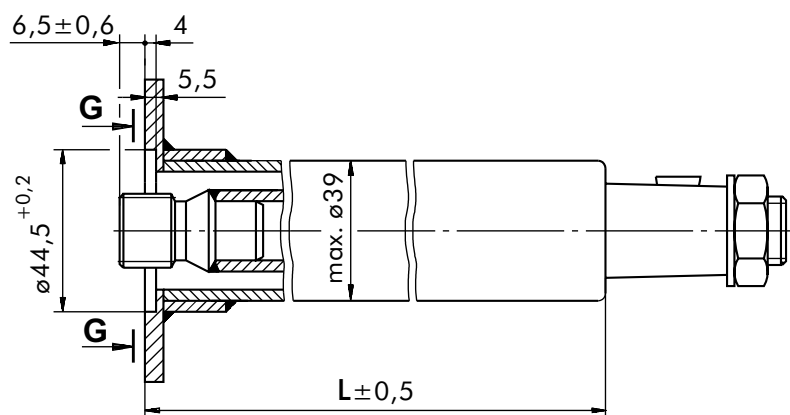
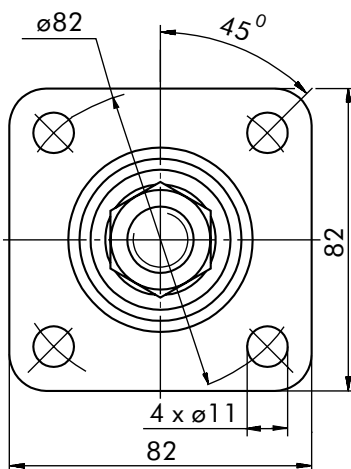

Type KKF

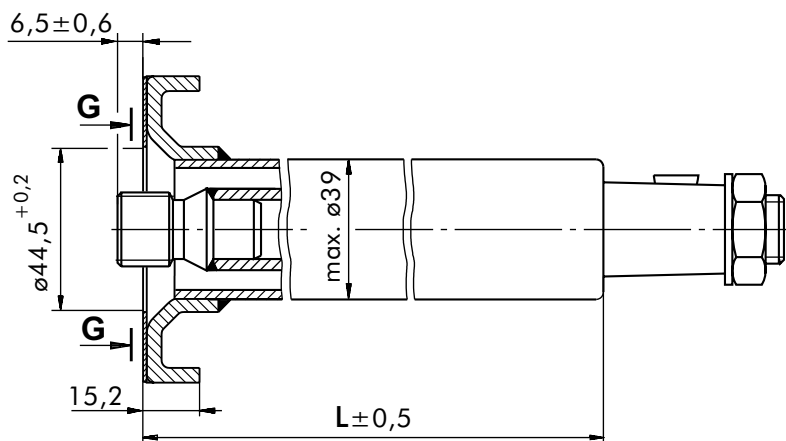
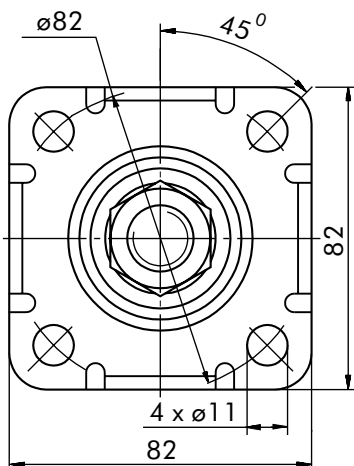

SPECIFICATION DATA

Parameters	Type			
	KK 75	KK 150	KK 390	KK 750
L, [mm]	78	168,2	393	777,8
Weight, [kg]	0,75	1,1	1,9	3,3

Please, contact factory or your regional manager regarding other lengths.

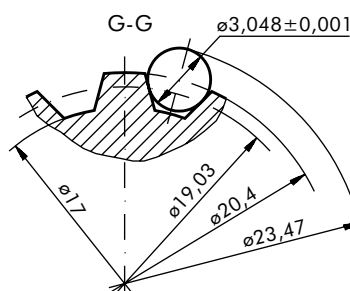

Involute Spline Data		
Modul	m	1,5875
Number of Teeth	z	12
Pressure Angle	α	30°
Pitch	p_t	4,986

SHAFT EXTENSIONS

TYPE I

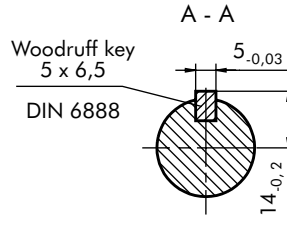
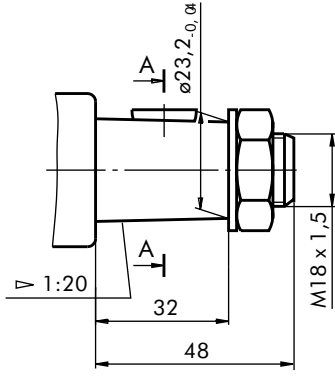

TYPE II

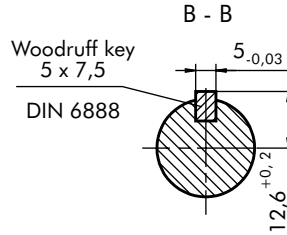
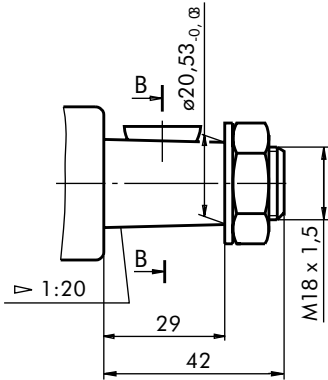

TYPE III

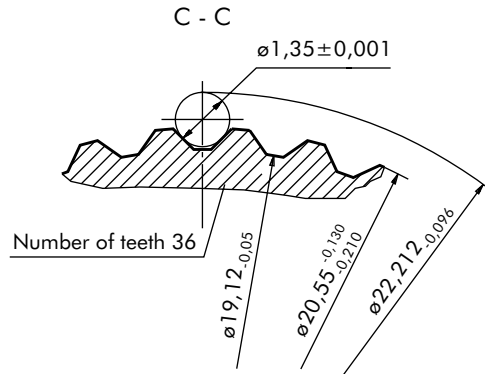
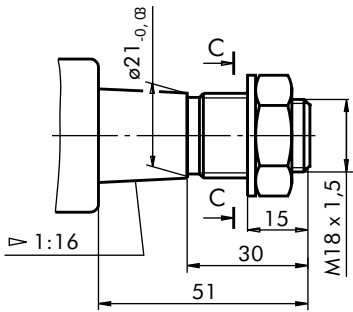

TYPE IV

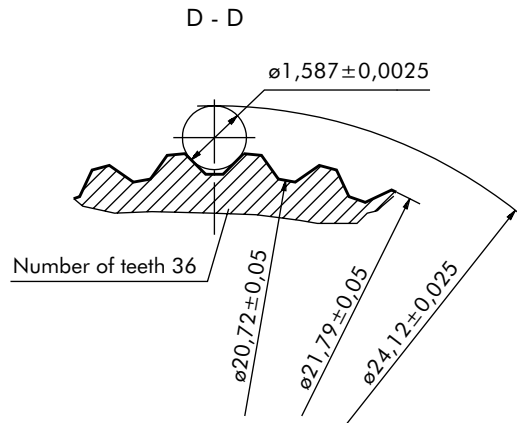
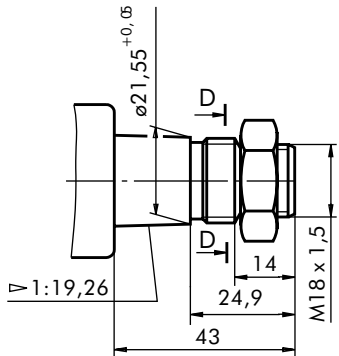

TYPE V

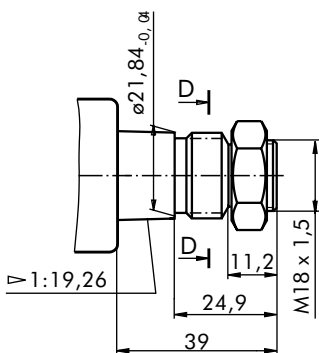

SHAFT EXTENSIONS

TYPE VI

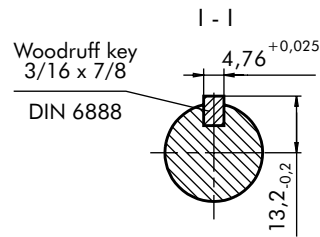
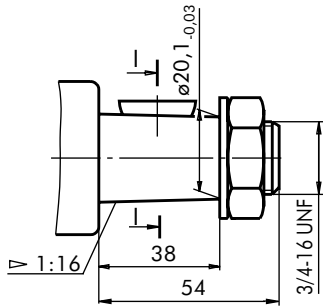

TYPE VII

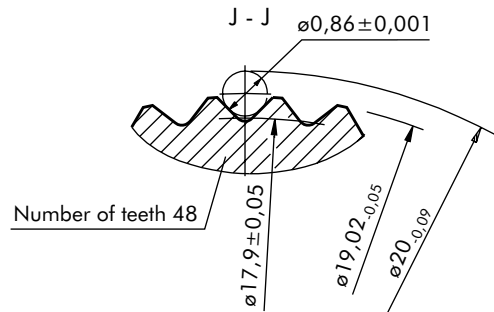
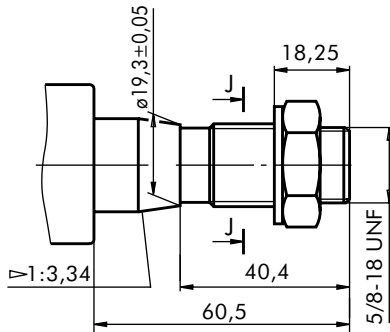

TYPE VIII

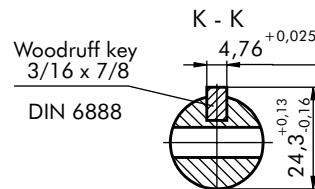
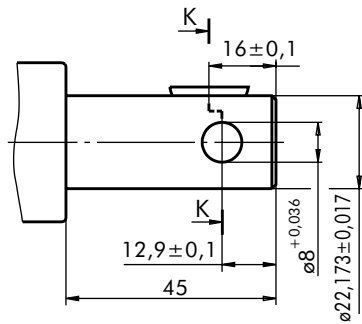

TYPE IX

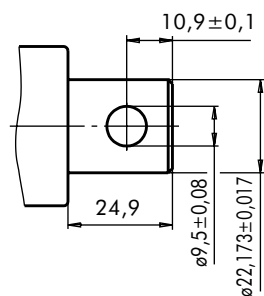

INSTALLING

For column type KK

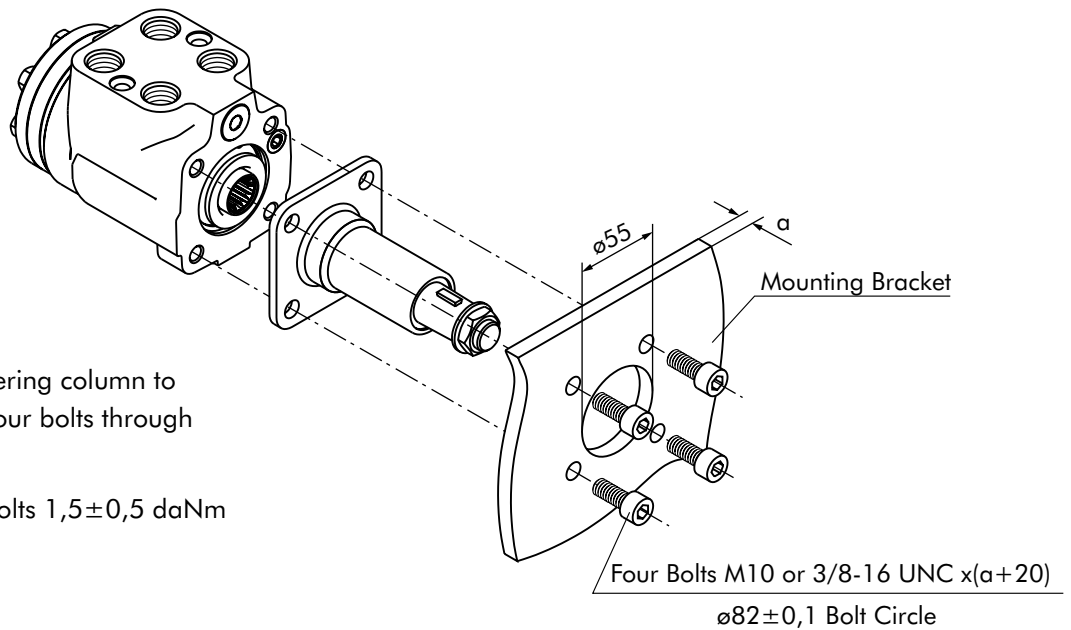

For assembling the Steering column to the Steering units use four bolts through mounting bracket.

Tightening torque for bolts $1,5 \pm 0,5$ daNm

For column type KKF

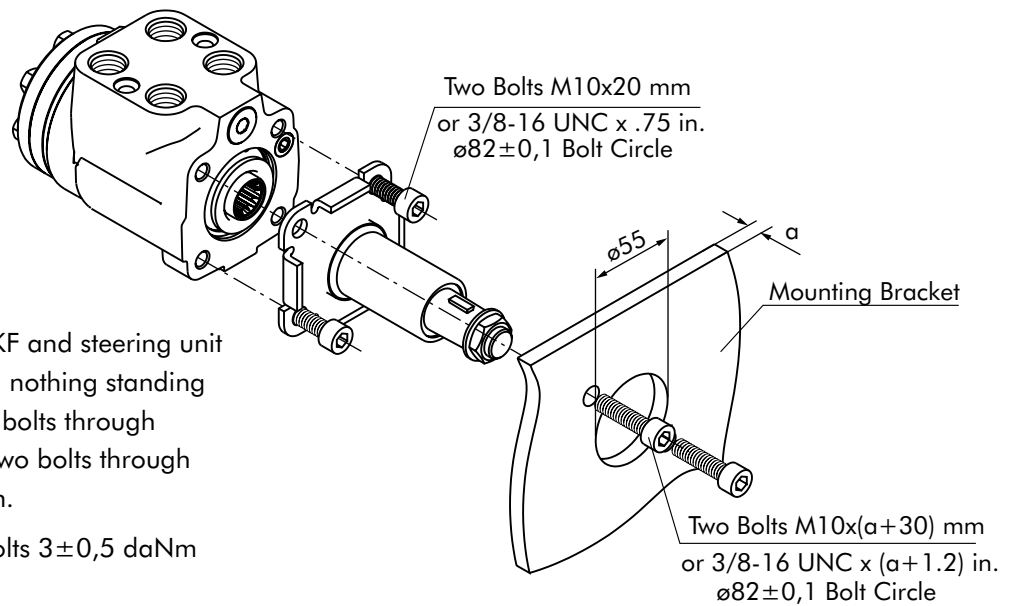

Steering column type KKF and steering unit must be assembled with nothing standing between them. Use two bolts through mounting bracket and two bolts through just the steering column.

Tightening torque for bolts $3 \pm 0,5$ daNm

Minimum Clearance at Assembly

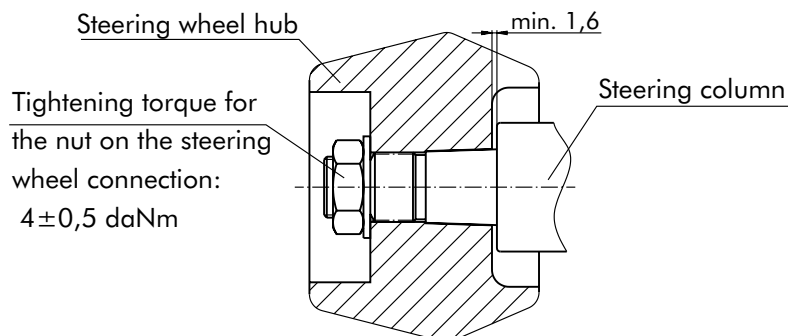

SOUND SIGNAL CONNECTION

E Option

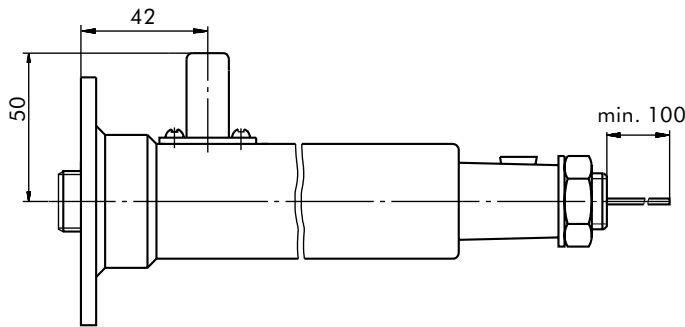

EE Option

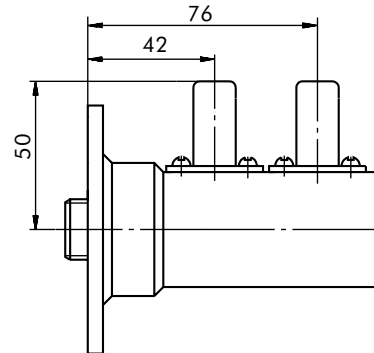

ORDER CODE

	1	2	3	4	5	6
KK						

Pos.1 - Mounting Flange

omit - Flange without Tabs

F - Flange with Tabs

Pos.2 - Length, mm (acc. to table)

Pos.3 - Shaft Extensions

I, II, III, IV, V, VI, VII, VIII, IX

Pos.4 - Signal Connection (Option)

omit - without electric signal connection

E - with one electric signal connection

EE - with two electric signal connection

Pos.5 - Option (Paint)*

omit - No Paint

P - Painted

PC - Corrosion Protected Paint

Pos.6 - Design Series

omit - Factory specified

NOTES:

* Colour at customer's request.

The steering columns are yellow galvanized as standard.

Shaft End Part

Order No:46415 001 00

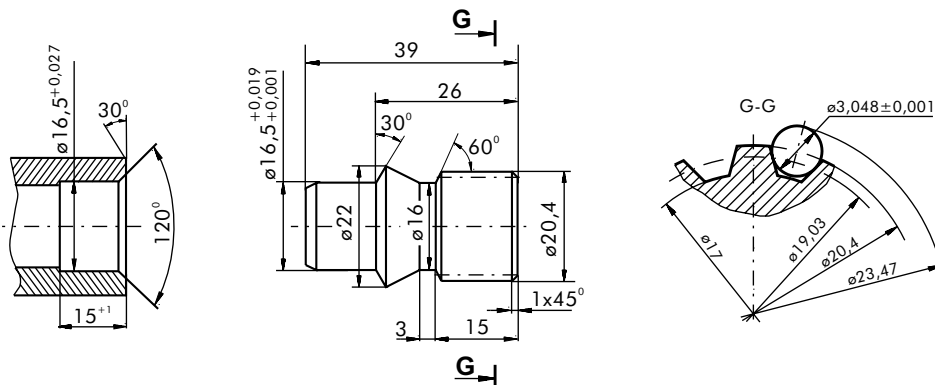

Involute Spline Data		
Modul	m	1,5875
Number of Teeth	z	12
Pressure Angle	α	30°
Pitch	p_t	4,986