

HYDRAULIC MOTORS MH

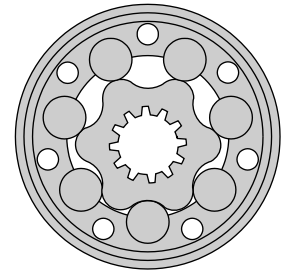

APPLICATION

- » Conveyors
- » Feeding mechanism of robots and manipulators
- » Metal working machines
- » Textile machines
- » Machines for agriculture
- » Food industries
- » Mining machinery etc.



CONTENTS

Specification data	39
Function diagrams	40 ÷ 42
Permissible shaft loads	43
Dimensions and mounting ...	44
Shaft extensions	45
Order code	45

OPTIONS

- » Model- Spool valve, roll-gerotor
- » Flange mount
- » Shafts- straight, splined and tapered
- » Metric and BSPP ports
- » Other special features

GENERAL

Displacement, [cm ³ /rev.]	201,3 ÷ 502,4
Max. Speed, [RPM]	150 ÷ 370
Max. Torque, [daNm]	51 ÷ 85
Max. Output, [kW]	11 ÷ 16
Max. Pressure Drop, [bar]	175 ÷ 125
Max. Oil Flow, [l/min]	75
Min. Speed, [RPM]	5 ÷ 10
Pressure fluid	Mineral based- HLP(DIN 51524) or HM(ISO 6743/4)
Temperature range, [°C]	-30 ÷ 90
Optimal Viscosity range, [mm ² /s]	20 ÷ 75
Filtration	ISO code 20/16 (Min. recommended fluid filtration of 25 micron)

Oil flow in drain line

Pressure drop (bar)	Viscosity (mm ² /s)	Oil flow in drain line (l/min)
100	20	2,5
	35	1,8
140	20	3,5
	35	2,8

Pressure Losses

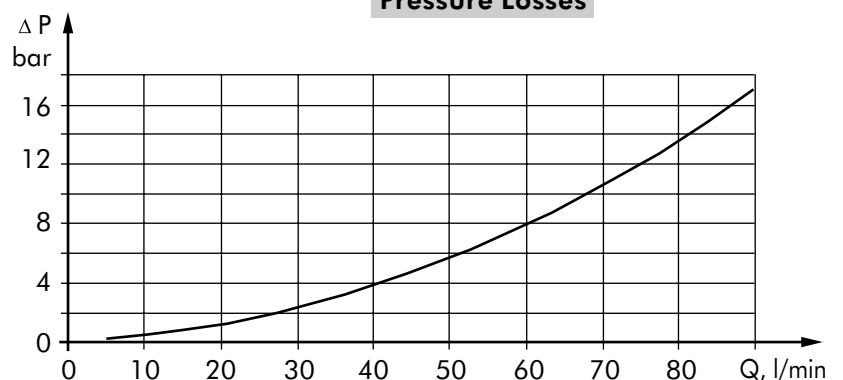

SPECIFICATION DATA

Type	MH					
	200	250	315	400	500	
Displacement, [cm ³ /rev.]	201,3	252	314,9	396,8	502,4	
Max. Speed, [RPM]	cont.	370	295	235	185	150
	int.*	445	350	285	225	180
Max. Torque [daNm]	cont.	51	61	74	84	85
	int.*	58	70	82	98	104
	peak**	64	79	98	109	117
Max. Output, [kW]	cont.	16	16	14	12,5	11
	int.*	18,5	18,5	15,5	15	14
Max. Pressure Drop [bar]	cont.	175	175	175	155	125
	int.*	200	200	200	190	160
	peak**	225	225	225	210	180
Max. Oil Flow [l/min]	cont.	75	75	75	75	75
	int.*	90	90	90	90	90
Max. Inlet Pressure [bar]	cont.	200	200	200	200	200
	int.*	225	225	225	225	225
	peak**	250	250	250	250	250
Max. Starting Pressure with Unloaded Shaft, [bar]	5	5	5	5	5	
Min. Starting Torque [daNm]	at max. press. drop cont.	39	52	66	72	72
	at max. press. drop int.*	45	59	73	88	88
Min. Speed***, [RPM]	10	10	8	5	5	
Weight, avg. [kg]	10,5	11	11,5	12,3	13	

* Intermittent operation: the permissible values may occur for max. 10% of every minute.

** Peak load: the permissible values may occur for max. 1% of every minute.

*** For speeds of 5 RPM lower than given, consult factory or your regional manager.

- 1) Intermittent speed and intermittent pressure must not occur simultaneously.
- 2) Recommended filtration is per ISO cleanliness code 20/16. A nominal filtration of 25 micron or better.
- 3) Recommend using a premium quality, anti-wear type mineral based hydraulic oil, HLP(DIN51524) or HM(ISO6743/4).
If using synthetic fluids consult the factory for alternative seal materials.
- 4) Recommended minimum oil viscosity 13 mm²/s at 50°C.
- 5) Recommended maximum system operating temperature is 82°C.
- 6) To assure optimum motor life fill with fluid prior to loading and run at moderate load and speed for 10-15 minutes.

FUNCTION DIAGRAMS

MH 200

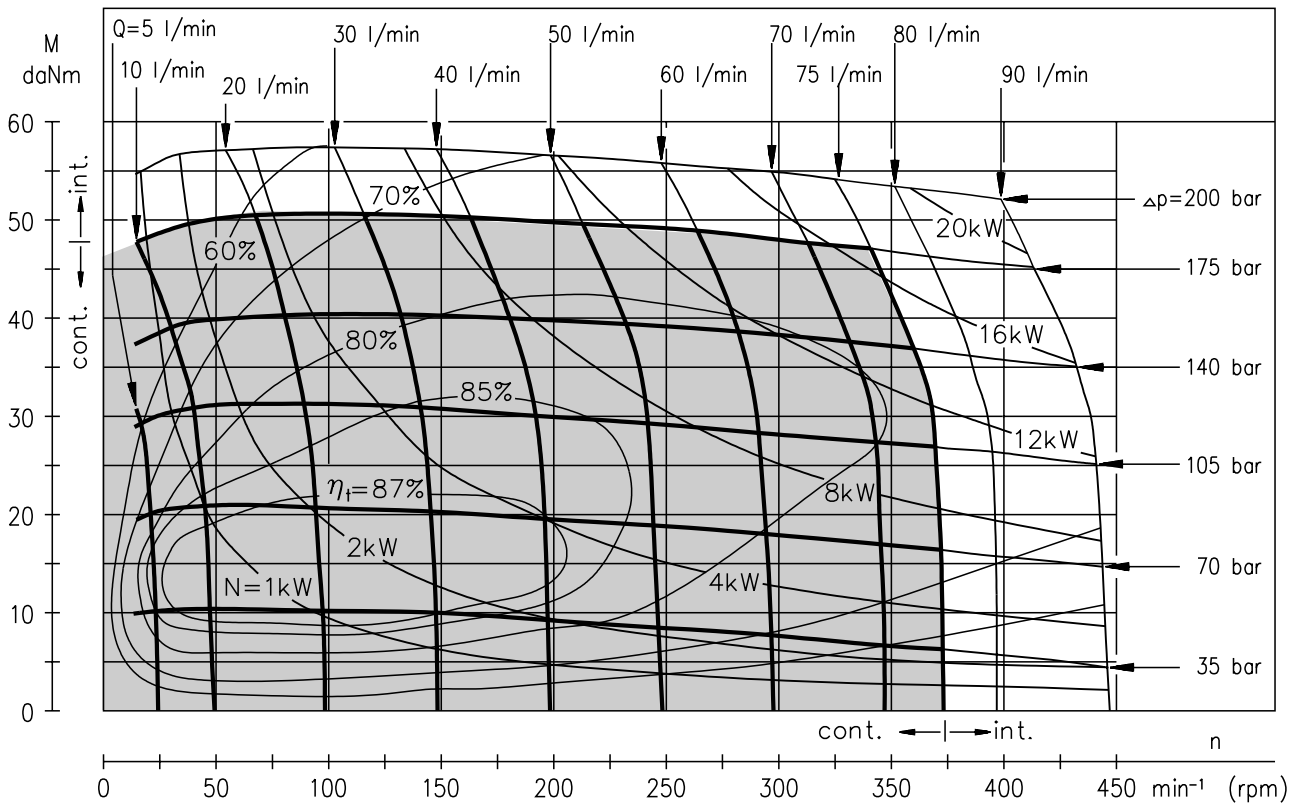

MH 250

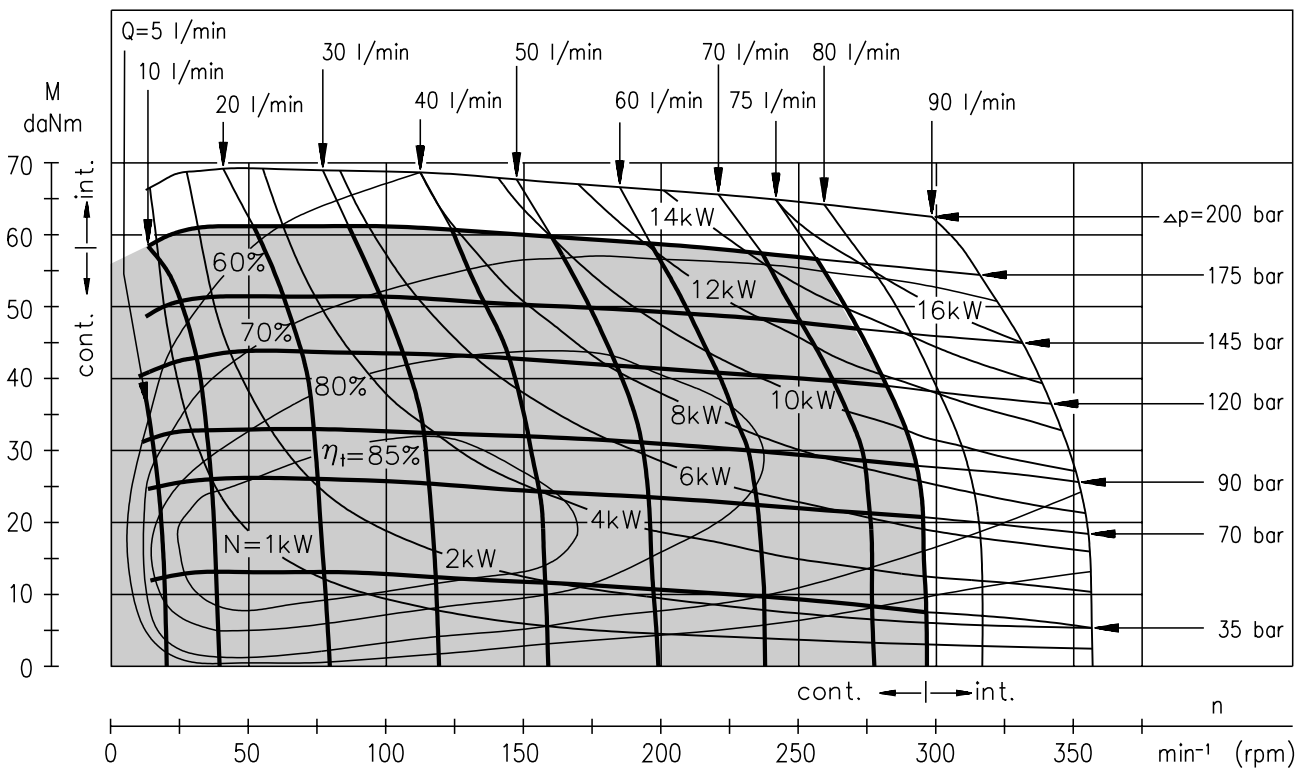

The function diagrams data was collected at back pressure 5 ÷ 10 bar and oil with viscosity of 32 mm²/s at 50° C.

FUNCTION DIAGRAMS

MH 315

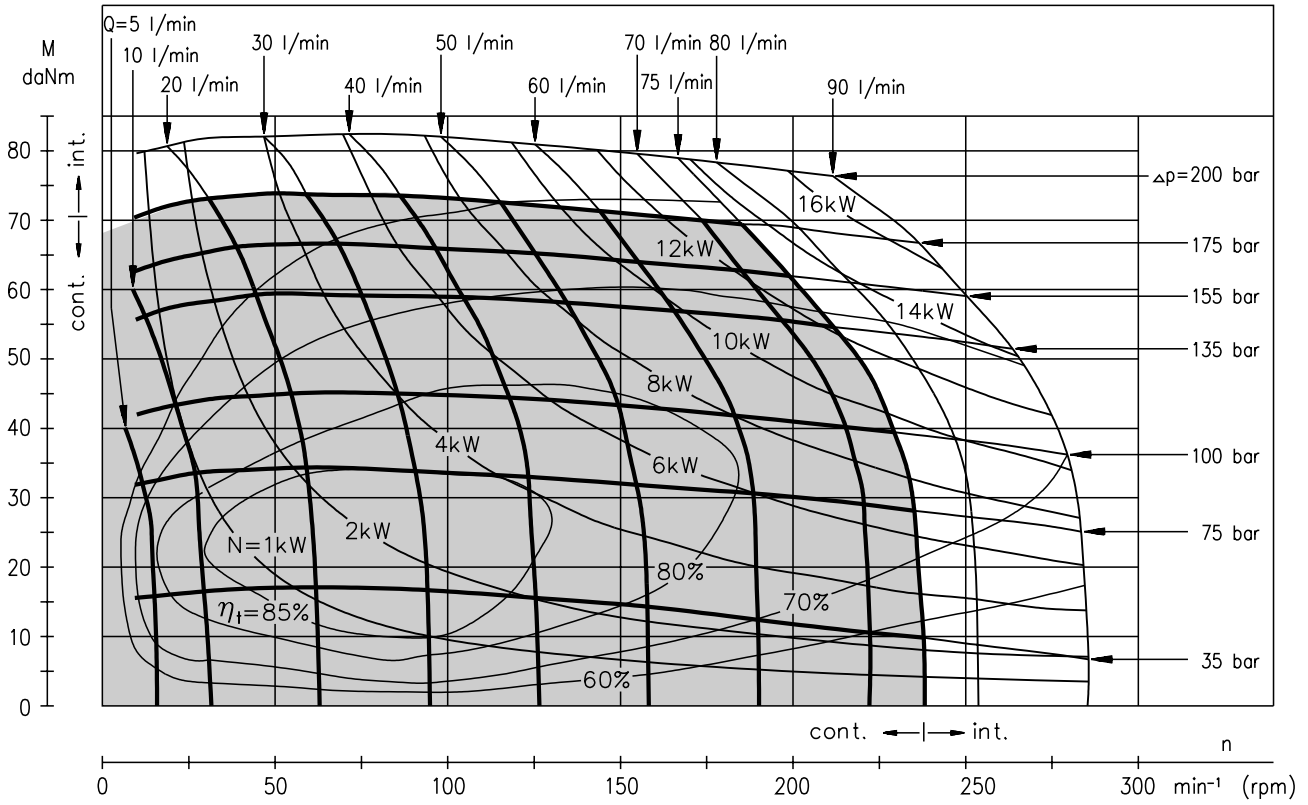

MH 400

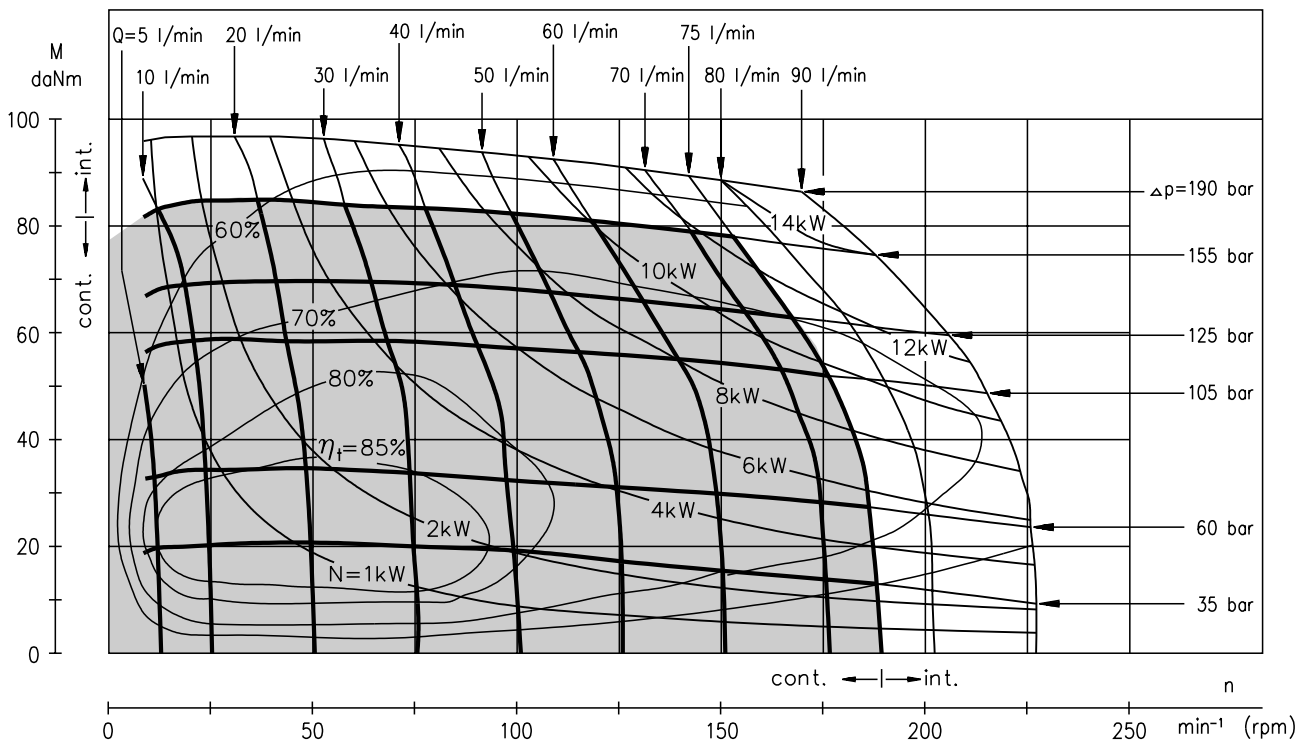

The function diagrams data was collected at back pressure 5 ÷ 10 bar and oil with viscosity of 32 mm²/s at 50° C.

FUNCTION DIAGRAMS

MH 500

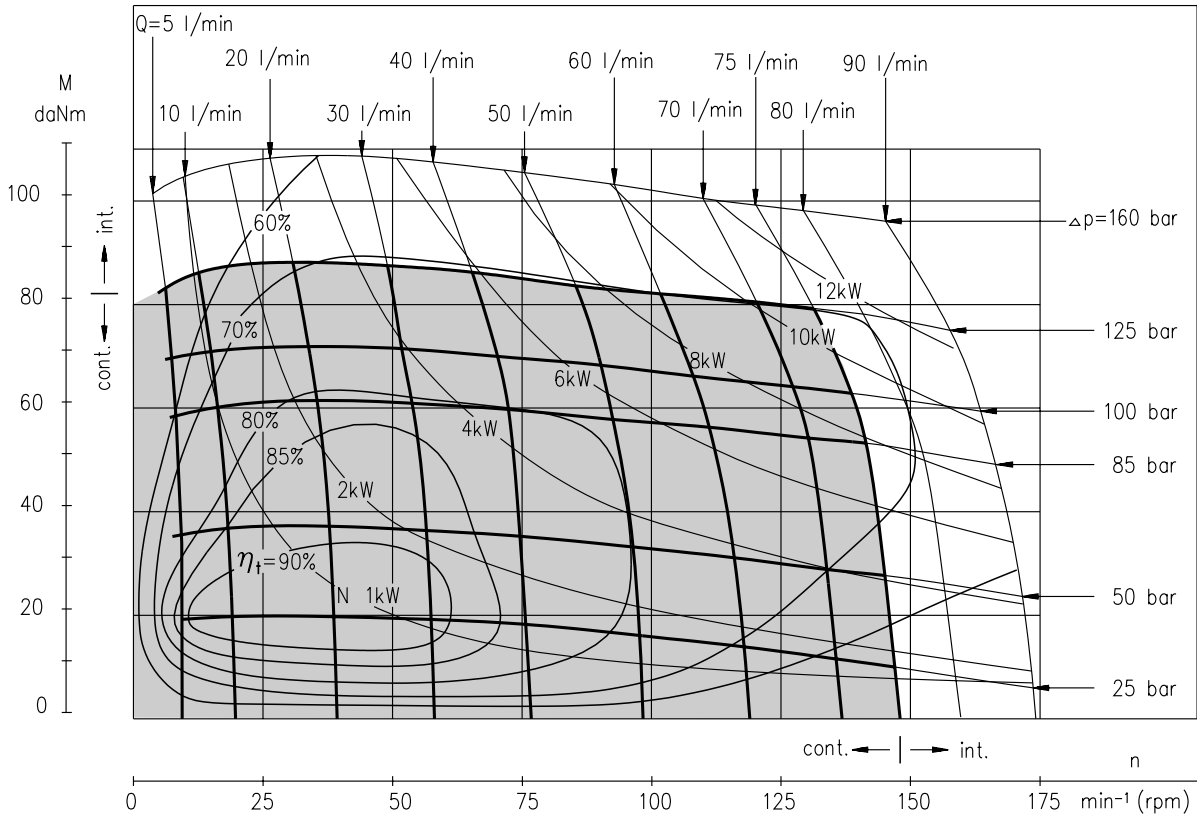

The function diagrams data was collected at back pressure 5 ÷ 10 bar and oil with viscosity of 32 mm²/s at 50° C.

PERMISSIBLE SHAFT LOADS FOR MH MOTORS

The permissible radial shaft load P_{rad} depends on the speed (RPM) and distance (L) from the point of load to the mounting flange.

$$\text{Radial Shaft Load } P_{\text{rad}} = \frac{1100}{n} \times \frac{25000}{103,5+L}, \text{ daN}^*$$

*L < 60 mm; n ≥ 200 min⁻¹

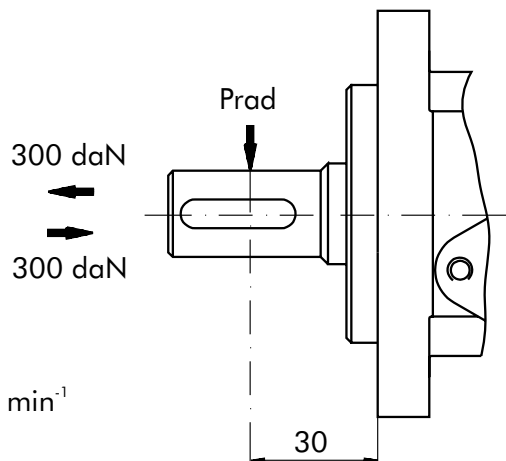
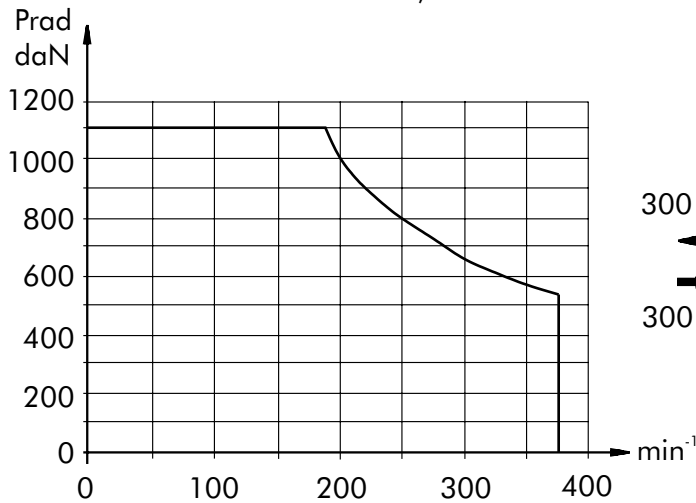

DIMENSIONS AND MOUNTING DATA

Magneto Maunt (4 holes)

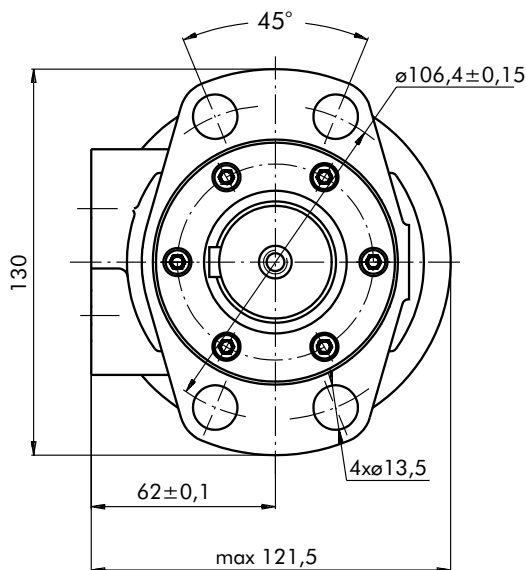
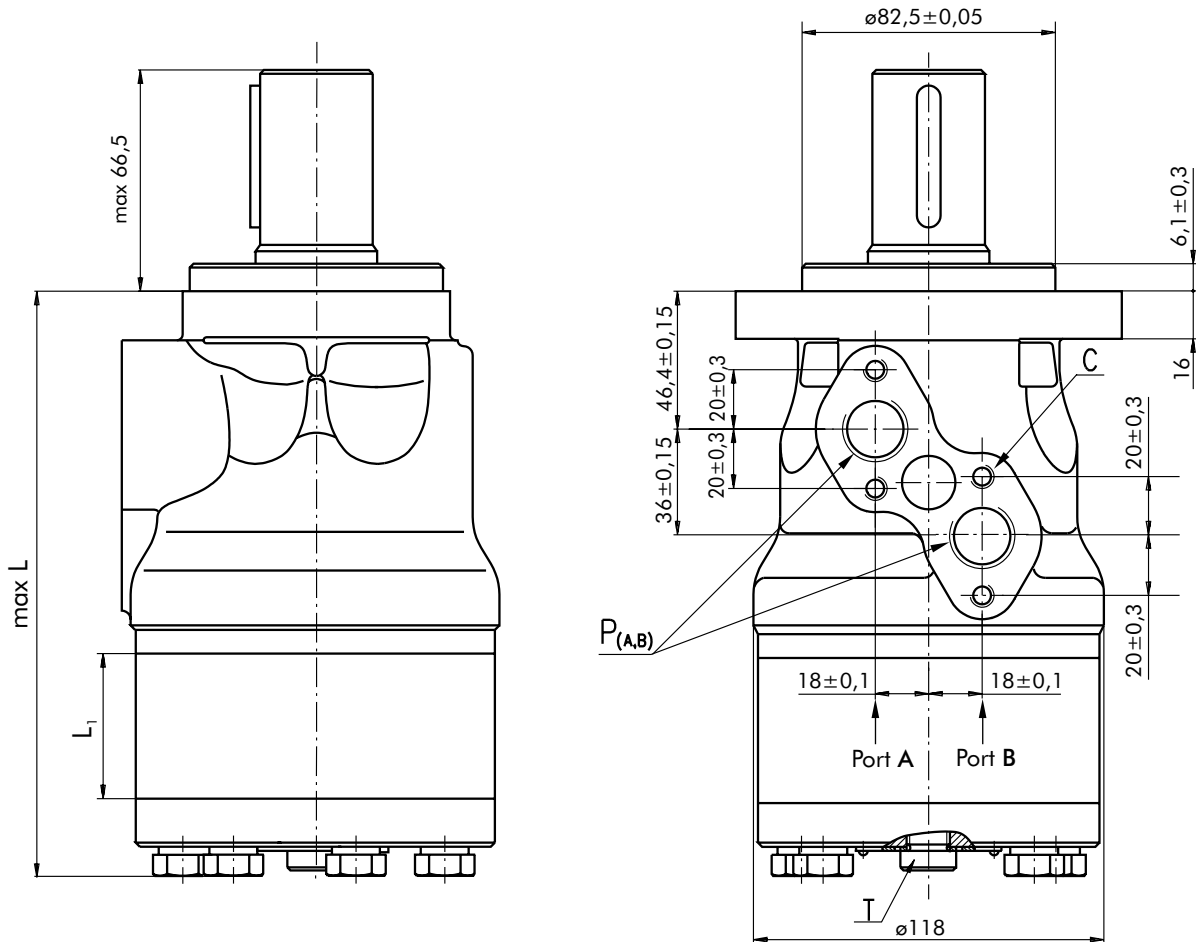

Type	L, mm	L ₁ , mm
MH 200	169	27,8
MH 250	176	34,8
MH 315	184	43,5
MH 400	196	54,8
MH 500	211	69,4

- C** : 4xM8-13 mm depth
- P_(A,B)**: 2xG1/2 or 2xM22x1,5-15 mm depth
- T** : G1/4 or M14x1,5-12 mm depth (plugged)

Standard Rotation
Viewed from Shaft End
Port A Pressurized - CW
Port B Pressurized - CCW

Reverse Rotation
Viewed from Shaft End
Port A Pressurized - CCW
Port B Pressurized - CW

MAX. PERMISSIBLE SHAFT SEAL PRESSURE FOR MH MOTORS

MH...U1 motors with high pressure seal and without drain connection:

The shaft seal pressure equals the average of input pressure and return pressure.

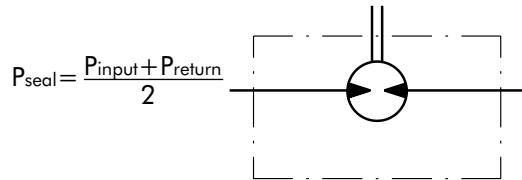

MH...U motors with high pressure seal and drain connection:

The shaft seal pressure equals the pressure in the drain line.

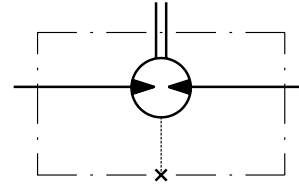

MH...1 motors with standard shaft seal and without drain connection:

The shaft seal pressure never exceeds the pressure in the return line.

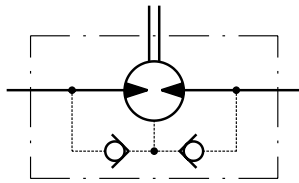

MH... motors with standard shaft seal and with drain connection:

The shaft seal pressure equals the pressure in the drain line.

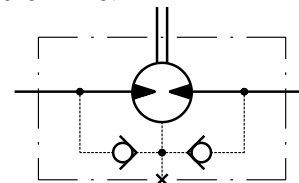

Max. return pressure without drain line or max. pressure in the drain line

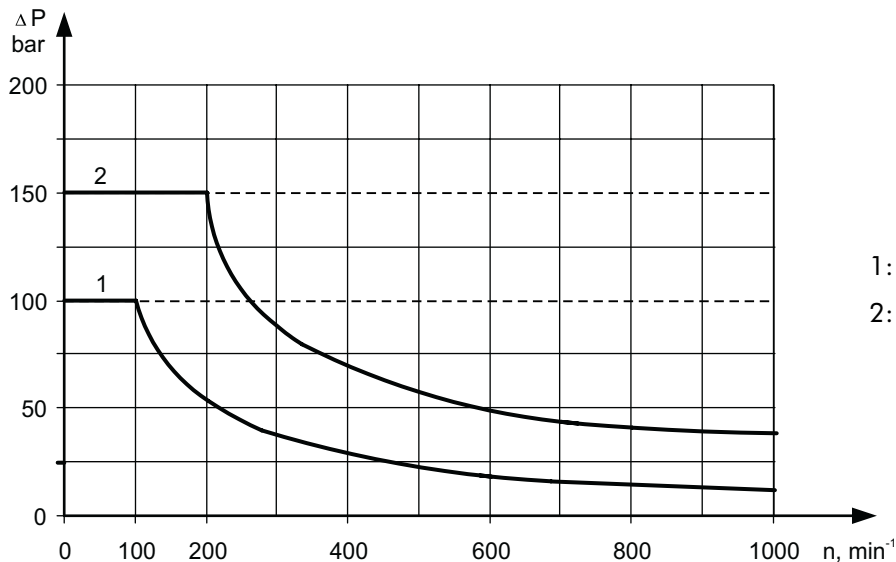

1: Drawing for Standard Shaft Seal
2: Drawing for High Pressure Seal ("U" Seal)

— - continuous operations
- - - - - intermittent operations

SHAFT EXTENSIONS

C - $\varnothing 32$ straight, Parallel key A10x8x45 DIN 6885
Max. Torque 77 daNm

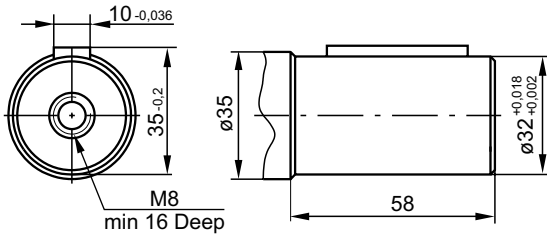

SH - $\varnothing 1\frac{1}{4}$ " splined 14T, DP 12/24 ANSI B92.1-1976
Max. Torque 95 daNm

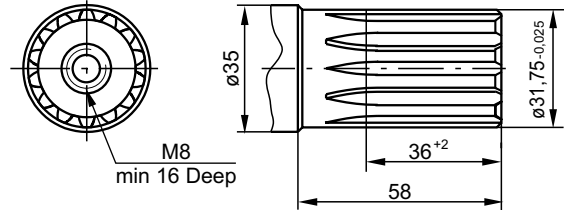

CB - $\varnothing 35$ straight, Parallel key A10x8x45 DIN 6885
Max. Torque 95 daNm

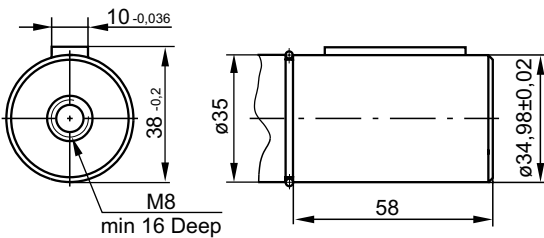

K - tapered 1:10, Parallel key B6x6x20 DIN 6885
Max. Torque 95 daNm

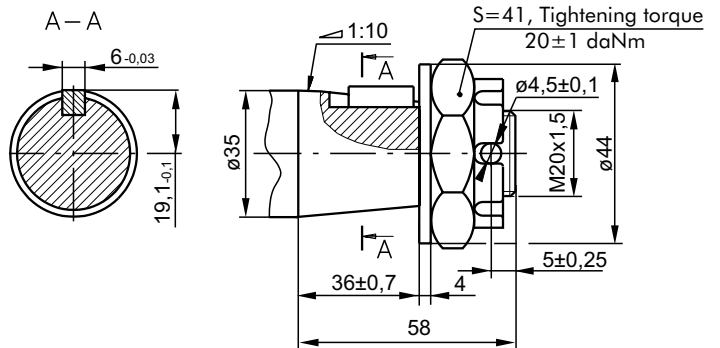

ORDER CODE

	1	2	3	4	5	6	7
MH							

Pos.1 - Displacement code

200	- 201,3 [cm ³ /rev]
250	- 252,0 [cm ³ /rev]
315	- 314,9 [cm ³ /rev]
400	- 396,8 [cm ³ /rev]
500	- 502,4 [cm ³ /rev]

Pos.2 - Shaft Extensions *

C	- $\varnothing 32$ straight, Parallel key A10x8x45 DIN 6885
SH	- $\varnothing 1\frac{1}{4}$ " splined 14T ANSI B92.1-1976
CB	- $\varnothing 35$ straight, Parallel key A10x8x45 DIN 6885
K	- $\varnothing 35$ tapered 1:10, Parallel key B6x6x20 DIN 6885

Pos. 3 - Shaft Seal Version (see page 44)

omit	- Standard shaft seal
U	- High pressure shaft seal (without check valves)

Pos. 4 - Drain Port

omit	- with drain port
1	- without drain port

Pos. 5 - Ports

omit	- BSPP (ISO 228)
M	- Metric (ISO 262)

Pos. 6 - Special Features (see page 46)

Pos. 7 - Design Series

omit	- Factory specified
------	---------------------

NOTES:

- * The permissible output torque for shafts must be not exceeded!
- The hydraulic motors are mangano-phosphatized as standard.